

ThorPlas Bearings

ENGINEERING MANUAL

For ThorPlas-Blue & ThorPlas-White

Version: TP2026.1

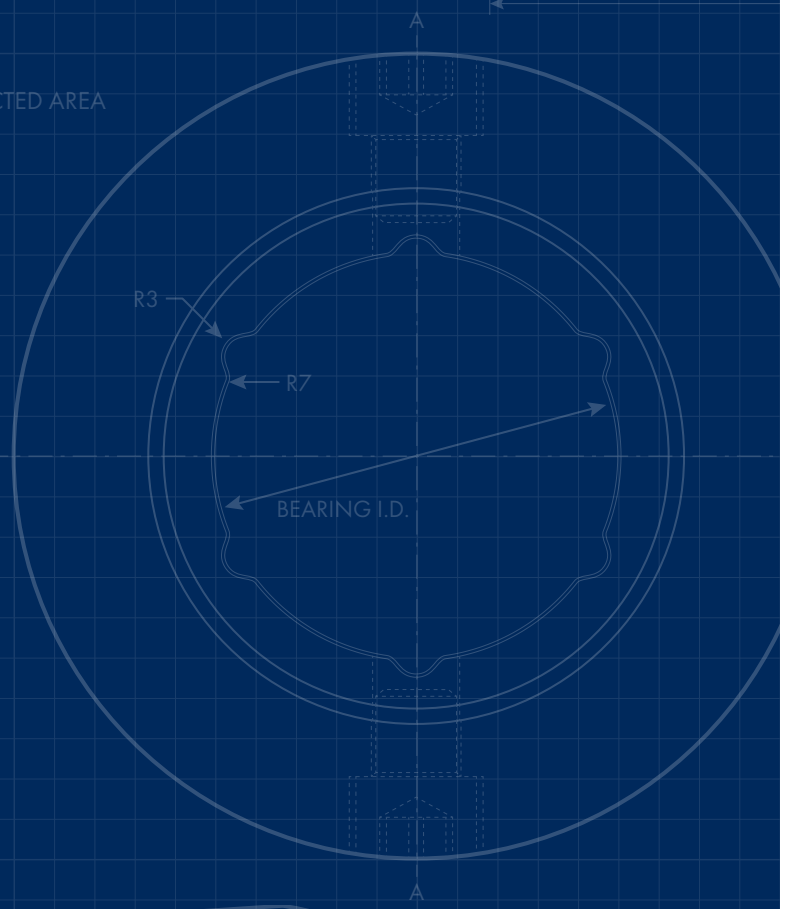
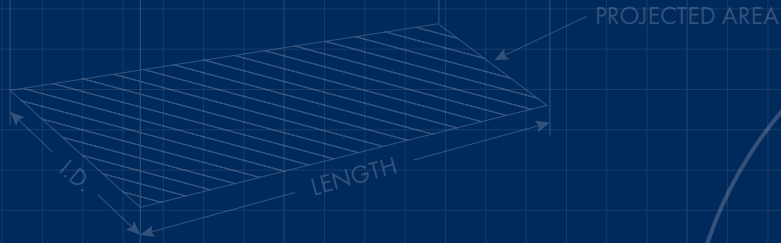
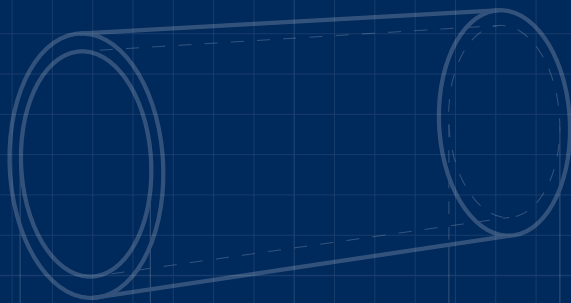

THOR DON

SYMBOLS AND UNITS

	Units	
	Metric	Imperial
C_t = Thermal Expansion Allowance	mm	inches
C_s = Absorption Allowance	mm	inches
d = Shaft Diameter	mm	inches
E_o = Modulus of Elasticity	MPa	psi
I.D. = Inside Diameter of Bearing	mm	inches
O.D. = Outside Diameter of Bearing	mm	inches
L = Length of Bearing	mm	inches
N = Shaft Speed	R.P.M.	R.P.M.
P = Pressure	MPa	psi
T_a = Machine Shop Ambient Temperature (Nominally 21°C (70°F))	°C	°F
T_o = Operating Temperature	°C	°F
W.T. = Wall Thickness of Bearing	mm	inches
α = Coefficient of Thermal Expansion	°C	°F
μ = Coefficient of Friction	-	-
V = Velocity	m/sec.	ft./min.
γ = Poisson's Ratio		

APPROXIMATE COMPARISON OF VARIOUS HARDNESS SCALES

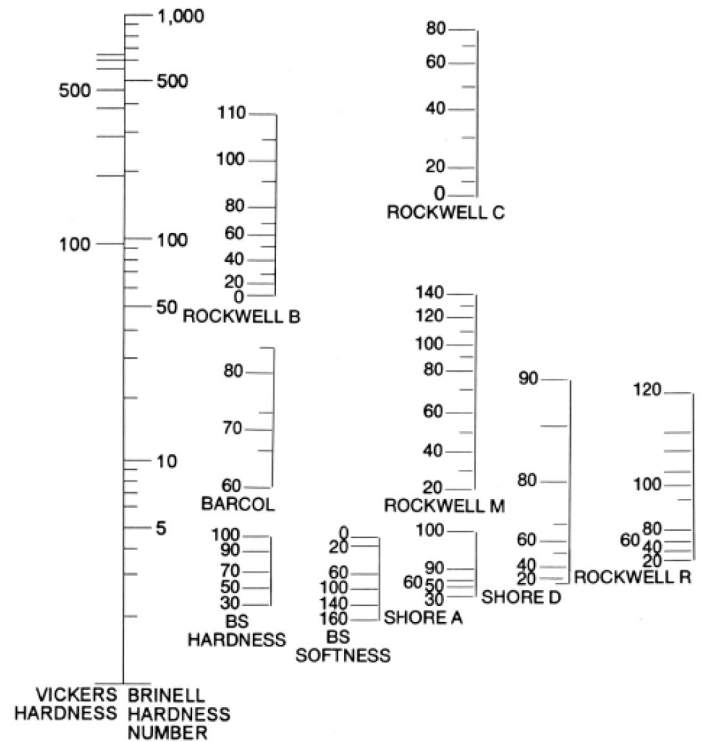

FREEZE FIT COOLANT TEMPERATURES

Dry Ice: -78°C (-109°F)

Liquid Nitrogen: -196°C (-320°F). Vapours ONLY. (See page 27)

Note: All clearances referred to in this manual are diametrical clearances.

METRIC CONVERSION TABLE

- Length
 - 1 Metre (m) = 39.37 Inches (in.)
 - 1 Millimetre (mm) = 0.03937 Inches (in.)
- Mass
 - 1 Kilogram (kg) = 2.205 lbs.
- Force
 - 1 Newton (N) = 0.2248 lbs.
- Pressure
 - * 1 kg/cm² = 14.223 psi (lbs./in.²)
 - ** 1 Mega Pascal (MPa) = 145 psi (lbs./in.²)
 - 1 N/mm² = 145 psi (lbs./in.²) = 1 MPa
 - 1 MPa = 10.197 kgf/cm²
 - 1 Bar = 1.019 kg/cm²
 - 1 Mega Pascal (MPa) = 10 Bar
 - * Kilo = 1,000
 - ** Mega = 1,000,000

OTHER THORDON TECHNICAL INFORMATION AVAILABLE

- a. Thordon Engineering Manual
(for Thordon elastomeric bearings)
- b. Thordon Bearing Sizing Calculation Program

Please contact your local Thordon Distributor or Thordon Bearings Inc. if you require any of the above.

INDEX

1. INTRODUCTION	04
2. PHYSICAL PROPERTIES	
a) General	05
b) Pressure	05
c) Friction	05
d) Self Lubrication	05
e) Effect of Water	05
f) Effect of Temperature	06
g) Material Stiffness	06
h) Chemical Compatibility	07
i) Typical Physical Properties	08
3. DESIGN GUIDE	
a) Application Analysis	09
b) Bearing Pressure	09
c) Velocity	09
d) PV Limits	10
e) Water Flow Grooves	10
f) Wall Thickness	11
g) Mating Surface	12
h) Fitting	12
i) L/D Ratio	12
j) Abrasive Environment	12
k) Impact and Shock Loads	12
4. APPLICATION DESIGN	
a) Application Analysis	13
b) Interference	13
c) Bore Closure	13
d) Running Clearance	13
e) Absorption Allowance	15
f) Thermal Expansion Allowance	15
g) Machining Tolerances	16
h) Minimum Installed Clearance	17
i) Machined Bearing OD	17
j) Bearing ID and Wall Thickness	17
k) Bearing Length	17
l) Bearing Retention	18
m) Using the Thordon Bearing Sizing Calculation Program	18
n) Step-by-Step Manual Calculations	21
5. MACHINING INSTRUCTIONS	
a) General Raw Material Cutting	23
b) General Machining	23
c) Groove Cutting	23
d) Chamfers	24
e) Step-by-Step Machining Process	24
f) Machining Tolerances	26
6. INSTALLATION GUIDELINES	
a) Freeze Fit Installations	27
b) Press Fit Installations	27
APPENDIX 1	
Shaft and Housing Tolerances	29
WARRANTY	30

1. INTRODUCTION

Thordon Bearings produces several bearing grades that offer specific operating advantages in different applications. The ThorPlas family of products - ThorPlas-Blue and ThorPlas-White has been formulated to complement the existing range of Thordon elastomer bearing grades and significantly expands the range of applications where Thordon bearings can be specified, while still maintaining many of the recognized Thordon performance benefits. Compared to Thordon elastomer bearings, The ThorPlas family offers better dimensional stability in water and through a wide range of temperatures, so can be installed with tighter clearances in applications such as vertical pumps.

Proprietary engineered thermoplastics, the ThorPlas family of materials are homogeneous, self-lubricating polymer materials, offering low friction and typically installed in a full-form, interference-fit bearing configuration.

ThorPlas-Blue was formulated for use in hydro-turbine wicket gate and operating linkage applications, as well as for high pressure industrial and marine bearing applications capable of withstanding operating pressures up to 45 MPa (6527 psi). Other applications where ThorPlas-Blue has performed successfully include vertical pumps and marine deck equipment where oil and grease have been eliminated.

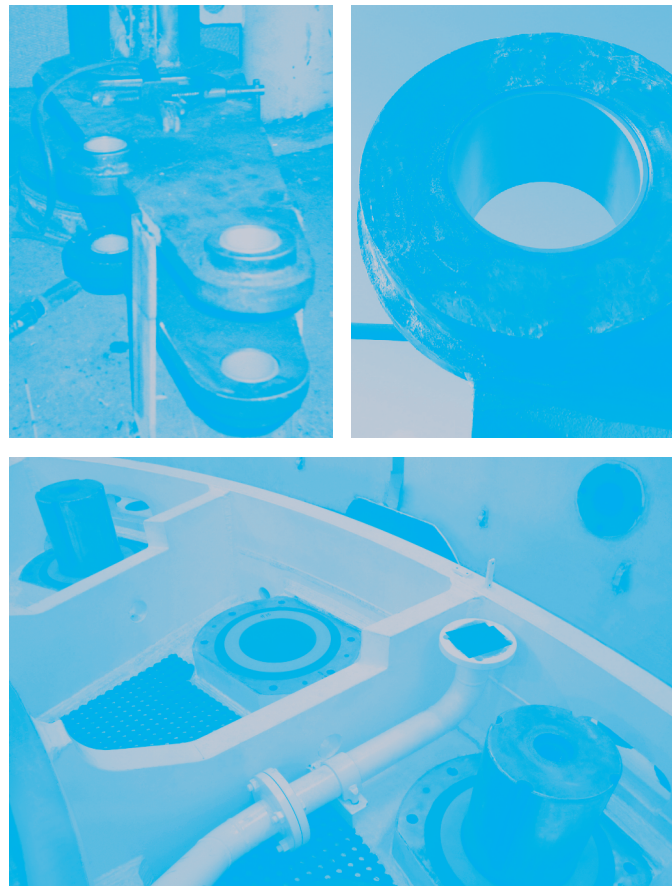

ThorPlas-White is an engineered thermoplastic alloy that was specifically developed to operate as a component used in the processing, production, or packaging of food products. It is a bearing material that can operate in equipment that is used for the treatment & distribution of potable water. It has been approved by the NSF International Certification for NSF/ANSI 61 as well as NSF/ANSI 51. The latter is the highest certification achievable for food equipment which includes direct food contact with all food types. NSF International Standard/American National Standard for Food Equipment, designated as an ANSI standard dated October 5, 2014 published by NSF International, states that '21 C.F.R. §§170 – 199, Food and Drug' document constitutes provisions of the NSF/ANSI 51 Standard. Based on the above certification and standard, ThorPlas-White complies with FDA regulations. ThorPlas-White also received WRAS (Water Regulations Advisory Scheme) approval in January 2014.

The guidelines in this manual have been developed to ensure that the ThorPlas family of products is designed, machined and installed correctly. They will also help to ensure the safety of all personnel during the handling, machining and installation of the ThorPlas material.

This information is offered as part of our service to customers. It is intended for use by persons having technical training and skill, at their own discretion and risk. All operations should be performed by individuals using suitable protective equipment.

If there are any questions regarding the procedures or performance of any of the ThorPlas products, contact Thordon Bearings Inc. at (905) 335-1440 or by e-mail: info@thordonbearings.com

The company reserves the right to change or amend any specification without notice. The sole, exclusive and only responsibility of Thordon Bearings Inc. ('the Company') to any customer or distributor of the Company's products for any claims, damages, losses or liabilities arising out of, or relating to, any products supplied by the Company, and the Company's sole, exclusive and only warranty shall be in accordance with the Company's Limited Warranty and statements limiting its liability set out on page 30 of this manual. In no event whatsoever shall the Company be liable for special, indirect, or consequential damages.

2. PHYSICAL PROPERTIES

a) General

The development of the ThorPlas family of products is part of Thordon's ongoing program of creating new bearing materials to meet specific needs. Thordon recognized the need for a high pressure, low friction homogeneous bearing material that could be installed as a full form (not requiring a metal or other rigid backing) bearing. The ThorPlas family was first introduced in 2001, and is the result of more than 10 years of research.

The main properties and features of the ThorPlas family are:

- Proprietary grades, crystalline, lubricated engineering thermoplastics
- Wear/abrasion resistance
- Low friction, self-lubricating, high pressure-velocity (PV) limit
- Dimensional stability through the normal range of working temperatures
- Strength and low creep
- Maximum continuous service temperature in water or oil: 80°C (176°F).

Note: Anti-rotation devices required above 70°C (158°F)

- Maximum continuous service temperature in air: 110°C (230°F).

Note: Anti-rotation devices required above 70°C (158°F)

- Minimal water absorption
- Chemical resistance
- Easily machined without affecting the coefficient of friction or the self-lubricating properties

The following applications take full advantage of the engineered thermoplastic alloy properties. The maximum dynamic design pressure of 45 MPa (6527 psi) for ThorPlas-Blue and ThorPlas-White is high enough that the material can be used in virtually all water control mechanism applications in hydro turbines. The low friction and low water absorption make the material ideal for vertical pump applications, particularly where dry start-up is required. As the ThorPlas family operates grease free, it is perfect for highly loaded marine, industrial and food/beverage applications where grease lubrication is difficult and sporadic, causing failure of bronze and other metallic bearings.

b) Pressure

The high strength and low creep of the ThorPlas family of materials enables it to support high operating pressures. Maximum dynamic design pressure is 45 MPa (6527 psi) for ThorPlas-Blue and ThorPlas-White either operating dry or lubricated by water, oil or grease (for corrosion protection purposes).

Peak static pressure is 60 MPa (8702 psi).

c) Friction

The dry coefficient of friction is 0.10. (See Figure 3 on page 8)

In water, it is 0.10 – 0.17. Low friction enables ThorPlas-Blue and ThorPlas-White to be used in vertical pumps with dry startup requirements.

d) Self Lubrication

The ThorPlas materials are homogeneous polymers with lubricants to lower friction and wear formulated into the molecular structure. Once the bearing enters service and a transfer film of solid lubricant is established between the shaft and the bearing, friction stabilizes for the life of the bearing. Because the lubricants are evenly dispersed throughout the material, machining has no adverse effect on its properties.

e) Effect of Water

Long term testing of the ThorPlas family of materials indicates that water absorption is minimal. For design purposes a factor of 0.15% of wall thickness is used for water absorption. The same factor is also used for oil or grease absorption.

When the ThorPlas family is subjected to continuous immersion in hot water, i.e. above 80°C (176°F), the material chemically deteriorates over time due to a reaction with the hot water. This deterioration or breakdown is known as hydrolysis. The surface of the material softens initially and then eventually cracks and breaks. Hydrolysis will also occur with other high temperature liquids with a high aqueous content.



Typical example of ThorPlas bearing with hydrolysis.

f) Effect of Temperature

The ThorPlas family of products are less affected by changes in temperature than most engineered plastics.

The coefficient of thermal expansion is $4.6e^{-5} \text{ } ^\circ\text{C}^{-1}$ or $2.5e^{-5} \text{ } ^\circ\text{F}^{-1}$. This thermal expansion allowance, although small, must be considered when dimensioning a ThorPlas bearing.

Retaining rings or mechanical retention should be used for temperatures over 70°C (158°F).

The maximum operating temperature in water is 80°C (176°F).

In a dry environment, the maximum operating temperature is 110°C (230°F).

g) Material Stiffness

Bearing stiffness is dependent on both size parameters and physical properties. The size parameters are the bearing length, diameter and wall thickness.

The physical property to be considered is the Compressive Young's Modulus (E_o) of the bearing material, which is equal to the compressive stress divided by the compressive strain. Bearing stiffness can be roughly estimated from:

$$\text{Stiffness} = (L \times D \times E_o) / t$$

- where: L = Bearing Length: mm (in.)
 D = Bearing Diameter: mm (in.)
 E_o = Compressive Young's Modulus: MPa (psi)
 t = Wall Thickness (W.T.): mm (in.)

For bearings with equal size parameters the bearing material stiffness is directly proportional to the value of the Compressive Young's Modulus for the material. Figure 1 gives the value of the Compressive Young's Modulus of Elasticity (E_o) for various materials commonly used as bearings.

COMPRESSIVE YOUNG'S MODULUS OF ELASTICITY (E_o)

Material	E_o (MPa)	E_o (psi)
Thordon SXL	440	64,000
UHMWPE	480	70,000
Thordon XL	490	71,000
Thordon HPSXL	650	94,250
Laminated Phenolic	2,500	362,594
Nylon	2,750	400,000
ThorPlas Family	3,280	476,000
White Metal	33,500	4,860,000
Steel	206,900	30,000,000

Figure 1: Compressive Young's Modulus

In engineering calculations, the stiffness of bearing support structures is often in a range between 0.5 to 1.00 MN/mm (2.8 to 5.7×10^6 lbs/inch).

This is much less than the typical ThorPlas bearing stiffness of 40 to 150 MN/mm (224 to 860×10^6 lbs/inch).

As a result, the influence of bearing material stiffness (such as ThorPlas materials) are normally not considered in dynamic vibration calculations. If more detailed evaluation is required, contact Thordon Bearings.

h) Chemical Compatibility

THORDON CHEMICAL RESISTANCE CHART

Chemical/Fluid	ThorPlas®	Thordon Elastomers	Chemical/Fluid	ThorPlas®	Thordon Elastomers
Salt solutions (Aq.)	A	A	Hydrocarbon/fuels	A	A-D
Ammonium chloride	A	A	Aromatic hydrocarbons	A	D
Calcium chloride	A	A-B	Benzene	A	D
Cupric chloride	A	A	Toluene	A	D
Magnesium chloride	A	A	Xylene	A	D
Potassium chloride	A	A	Aliphatic – gasoline, grease	A	A-B
Sodium chloride	A	A-B	Lubricating oils (petroleum)	A	B
Weak acids (Aq.)	A-B	B-D	Liquid propane gas	A	B-C
Acetic acid	B	D	Chlorinated Solvents	C-D	D
Benzoic acid	A	D	Ethylene Chloride	C	D
Boric acid	A	A-B	Chloroform	C	D
Carbonic acid	A	A	Alcohols	A	D
Chromic acid	A	D	Ethanol	A	D
Citric acid	A	A	Methanol	A	D
Formic acid, 5%	A	D	Isopropyl alcohol	A	D
Lactic acid	A	B-D	Ketones	A-B	D
Strong acids	A-C	B-D	Methyl ethyl ketone	A	D
Hydrochloric, 10%	C	B	Acetone	B	D
Nitric acid, 0.1%	A	C	Ethers	A	D
Phosphoric acid, 3%	A	A	Diethyl ether	A	D
Sulphuric, 5%	A	B-C	Isopropyl ether	A	B
Sulphuric, concentrated	C	D	Esters	A	D
Weak bases	A-B	A-C	Ethyl acetate	A	D
Ammonia 10% Aq.	A	A	Methyl acetate	A	D
Magnesium hydroxide, 10%	B	C	Freon 12	A	A-C
Potassium carbonate	A	B	Detergents, Organic	A	B-D
Sodium carbonate	A	B	Castor oil	A	A-B
Triethanolamine	B	B-D	Silicone fluids	A	A
Strong bases	C-D	B	Vegetable Oils	A	A-B
Potassium hydroxide, 10%	C	B			
Sodium hydroxide, 10%	C	B			
Oxidizing agents	A	B-C			
Hydrogen peroxide, 1 – 3%	A	B			
Chromic acid	A	C			

A: Excellent-No Affect; B: Good-Little Affect; C: Fair-Moderate Affect; D: Unacceptable

Figure 2: Thordon Chemical Resistance Chart

i) ThorPlas Family Typical Physical Properties

THORPLAS TYPICAL PHYSICAL PROPERTIES - METRIC & IMPERIAL

Property	Unit of Measure	Value	
Specific Gravity	–	1.40	
Hardness (ASTM D2240)	Shore-D	83	
Ultimate Tensile Strength (ASTM D638)	MPa (psi)	66 (9,600)	
Elongation at Break	%	~10	
Tensile Modulus of Elasticity (ASTM D638)	MPa (psi)	2,930 (425,000)	
Compressive Strength (ASTM D695)	MPa (psi)	>400 (58,000)	
Compressive Stress at Yield (2% offset) (ASTM D695)	MPa (psi)	91 (13,200)	
Compressive Young's Modulus of Elasticity (ASTM D695)	MPa (psi)	3,280 (476,000)	
Notched Impact Resistance (ASTM D256)	J/m (ft.lb/in.)	40 (0.75)	
Coefficient of Friction			
Dry (ASTM D3702) 0.27MPa or 40psi	–	0.15-0.30	
Dry (>200 bar or >3000psi)	–	~0.1	
Wet (>200 bar or >3000psi)	–	0.10 – 0.17	
Abrasive Wear (Rotary Drum Dry Abrasion) (ASTM D5963)	mm ³ (in. ³)	~200 (0.012)	
Thermal Conductivity	W/m-k (Btu/hr-ft.F)	~0.25 (~0.14)	
Coefficient of Thermal Expansion (ASTM D696 modified)	cm/cm/°C (-20°C – 100°C)	4.6x10 ⁻⁵ (2.6x10 ⁻⁵)	
	(in/in/°F) (-4°F – 212°F)		
Absorption % in Water (22°C) (ASTM D570)	24-hr	Vol %	< 0.05
	Long-term	Vol %	< 0.15
Melting Temperature	°C (°F)	> 250 (> 480)	
Operating Temperatures – Min./Max.	Dry	°C (°F)	-50/110 (-58/230)
	Wet	°C (°F)	-10/80 (14/176)
<i>Note: Properties are typical values, unless otherwise noted, and may be altered to some extent by processing conditions.</i>			

Figure 3: ThorPlas Typical Physical Properties - Metric & Imperial

3. DESIGN GUIDE

a) Application Analysis

The following information should be considered when evaluating an application where the ThorPlas family of products are to be used:

- shaft and housing dimensions
- bearing pressure
- shaft rotation and speed
- type, size and concentration of abrasive particles
- type of lubrication – lubricating medium and flow rate

b) Bearing Pressure

Nominal bearing pressure is calculated by dividing the radial load by the projected or cross sectional area.

The projected area is determined by multiplying the inside diameter (I.D.) of the bearing by the bearing length (L), as in Figure 4. The use of I.D. multiplied by bearing length (L) is a bearing industry norm for calculating the projected area for bearing pressure. Dividing the load by the projected area gives the approximate pressure. This assumes that the pressure is uniform across the area. In reality, the pressure is greatest at the 6 o'clock position and decreases in a parabolic curve to zero where the shaft starts to have clearance with the bearing. It is therefore advantageous, considering load carrying capacity, to keep running clearances to a minimum.

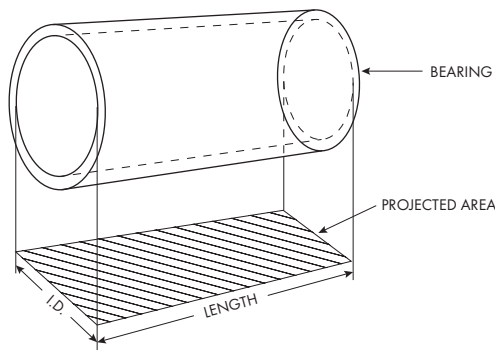

Figure 4: Bearing Pressure

Radial load needs to be defined as maximum design load, normal operating load or a combination of static and impact loads. Furthermore, it is important to define if the load is constant or cyclic.

$$\text{Nominal Bearing Pressure} = \frac{\text{Radial Load}}{\text{Projected Area}} = \frac{\text{Load}}{\text{Length} \times \text{I.D.}}$$

c) Velocity

The sliding velocity or the peripheral shaft speed is also an important design factor. Velocity is an essential consideration when evaluating frictional heat generation.

It is calculated by the following equation for rotating shafts.

$$V \text{ (m/sec)} = \frac{\pi dN}{60 \times 1000} = \frac{dN}{19,100}$$

or

$$V \text{ (fpm)} = \frac{\pi dN}{2} = 0.262 dN$$

where: V = Sliding Velocity

d = Shaft Diameter (mm or in.)

N = RPM of the shaft

π = pi constant 3.1416

The ThorPlas family of products can work at high pressures in oscillating motion or at slow full rotation rpm. For non-hydrodynamic operation, as the peripheral velocity increases, the load on the bearing should be reviewed in conjunction with the allowable PV limit as described in Figure 5 on page 10.

For applications outside the PV limits, please consult with Thordon Bearings Inc.

d) PV Limits – Sliding Operation

For proper bearing performance, two factors must be considered:

- operating pressure
- velocity at the contact surface

The result of multiplying the pressure by the linear velocity is referred to as a PV value. The combination of pressure and velocity causes heat generation at the bearing surface. If this heat is not removed from the bearing surface, it can cause premature bearing failure due to overheating and wear.

The PV limits in Figure 5 have been developed to ensure the proper design of the ThorPlas family of bearings.

PV LIMITS

Operating Condition	PV Limit (MPa - m/min.)	PV Limit (psi - fpm)
Full rotation – dry	7.35	3,500
Full rotation – cooled (water bath) ¹	24	12,000
Full rotation – continuous cool water supply	147	70,000

Figure 5: PV Limits

Note 1: The size of the water bath should be such that the heat generated by friction does not increase the water temperature above 80°C (176°F).

Note 2: For guidance on potential applications that fall outside the PV limits contact Thordon Bearings Inc. or your local Thordon distributor.

Note 3: PV values are given by many non-metallic material manufacturers and are often published with several incorrect assumptions. The first is that the individual P and V values have little importance, as long as they are with the product value range. The second, and perhaps the most dangerous assumption is the limited amount of test time used to develop the P and V values. No formal consideration is given to the time factor.

Note 4: These guideline values are supplied for reference only. PV limits for any material vary with different combinations of pressure and velocity as well as with other test conditions.

These limits do not apply where shaft speeds and loads are such that the bearing operates under hydrodynamic conditions.

e) Water Flow Grooves

For applications such as vertical pumps where there is a high peripheral velocity and an available flow of cooling water, grooves are machined in the I.D. of the bearing to facilitate the flow of the cooling water. Grooves for the ThorPlas bearings should be radiused (“u” type) to prevent chipping during machining, rather than the square grooves often used for Thordon elastomeric bearings. Figure 6 shows the standard groove configuration for a ThorPlas-Blue bearing while Figure 7 shows the groove dimensions.

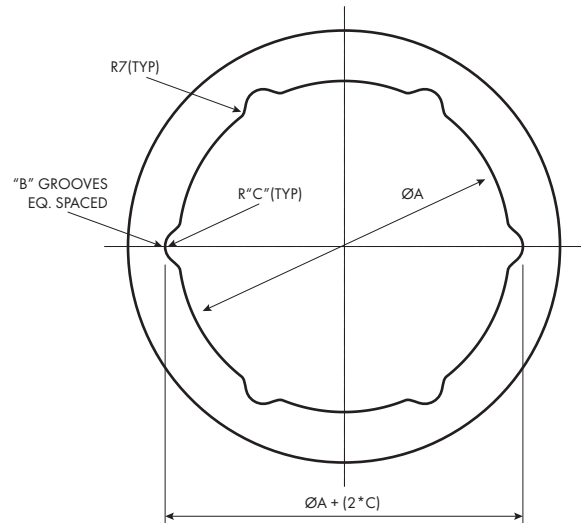

Figure 6: Typical Groove Configuration for the ThorPlas family of bearings

THORPLAS WATER GROOVE DIMENSIONS

A Shaft Diameter (mm)	A Shaft Diameter (in.)	B Number of Grooves	C Groove Radius (mm)	C Groove Radius (in.)
up to 30	up to 1.20	3	3	0.120
31 – 50	1.21 – 2.00	4	3	0.120
51 – 80	2.01 – 3.15	6	3	0.120
81 – 120	3.16 – 4.70	6	4	0.160
121 – 160	4.71 – 6.30	8	4	0.160
161 – 200+	6.31 – 7.90+	10	4	0.160

A, B and C refer to dimensions in Figure 6.

Note: Water grooves are only used when there is a flow of water through the bearing such as a vertical pump. Grooves are not required when a bearing is immersed in water with no significant flow, as in a wicket gate bearing application.

Figure 7: ThorPlas Water Groove Dimensions

f) Wall Thickness

A minimum wall thickness is required for the ThorPlas material to ensure that it can generate sufficient interface pressure for an interference fit. The typical minimum wall thickness for this is shown in Figure 8.

TYPICAL THORPLAS MINIMUM WALL THICKNESS GUIDE

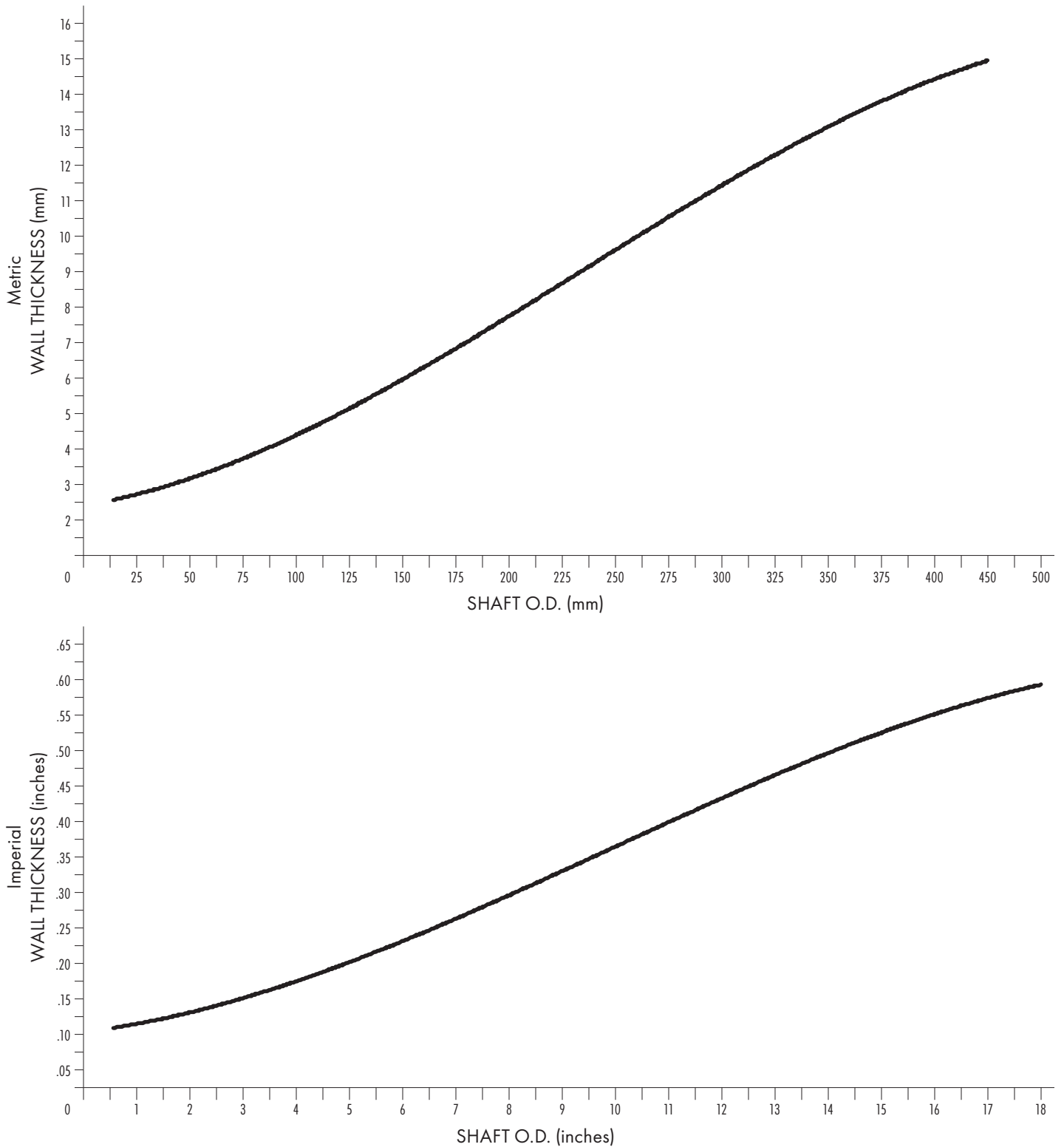

Figure 8: Typical ThorPlas Minimum Wall Thickness Guide

Notes: 1) If actual wall thickness is close to the minimum as indicated above, an increase in standard interference may be required to ensure that there is sufficient interface pressure to hold the bearing in place. See further comments in Application Design, page 13 (4b).

2) For grooved bearings, the minimum wall thickness is measured from the bottom of the groove to the bearing O.D. Thinner walls may be possible, contact Thordon Bearings for further information.

g) Mating Surface

Most common metallic mating surfaces perform well when used in conjunction with the ThorPlas family of bearings.

If corrosion is a concern, a corrosion resistant mating surface should be used. Stainless steel is frequently used for corrosion resistance. Bronze shafts or liners can also be used. Do not run ThorPlas on corroded surfaces as this will result in accelerated bearing wear. Common bronzes that work well include Gunmetal (88% Cu, 10% Sn and 2% Zn) or 70-30 Copper Nickel. While shaft hardness of 40 Rockwell C or above is preferred; satisfactory performance can be achieved with hardness in the range of 20 Rockwell C, depending on the amount and type of abrasives present.

ThorPlas products should not be operated against a non-metallic mating surface.

The surface finish of the mating shaft should be as smooth as practical to limit the initial bedding-in wear. Thordon testing has shown that less frictional heat is generated with a smoother shaft. For optimum performance, a final machined surface finish of 0.8 micro-metres (32 micro-inches) is recommended. Mating surface finishes up to 1.6 micro-metres (63 micro-inches) will perform satisfactorily. Where the application involves axial movement, the shaft finish should not exceed 0.8 micro-metres (32 micro-inches).

h) Fitting

ThorPlas bearings are usually fitted with an interference fit. Freeze fitting is recommended but press fitting can be used as long as care is taken to avoid direct impact on the material. A combination of freeze fitting and press fitting is recommended for bearings with high interference. See Section 6 - Installation Guidelines on page 27 for detailed freeze and press fitting instructions.

Bonding of ThorPlas bearings is not recommended.

If ThorPlas bearings are exposed to temperatures above 70°C (158°F) mechanical retention – retaining rings or pins – should be used.

Both the O.D. and I.D. of a ThorPlas bearing should ideally be machined prior to installation. Machining of the bearing I.D. after fitting should be avoided since it reduces the interference stresses, which are concentrated on the I.D. of the bearing. If unavoidable, less than 5% of wall thickness should be removed.

i) L/D Ratio

To facilitate installation and to provide reasonable bearing operation, typical recommended Length to Diameter ratios (L/D) for the ThorPlas family of materials are:

Maximum L/D ratio: 2:1

Minimum L/D ratio: 1:1

For larger or smaller L/D ratios, please consult with Thordon Bearings Inc.

j) Abrasive Environment

Although ThorPlas bearings are more abrasive resistant than the majority of metallic and non-metallic bearing materials, they will perform better if they have less contact with abrasives. For high pressure bearings which may be exposed to water, especially those with oscillating motion and no flow of water, Thordon recommends the use of Thorseals® in recessed grooves near the ends of the bearing to prevent abrasive ingress. In other cases, a clean water flush may offer a practical alternative.



ThorPlas Wicket Gate Bearing with Thorseal

k) Impact and Shock Loads

The ThorPlas family of products can withstand substantial impact and shock loading, however, the bearing must be fully supported in this type of application. For applications with significant shock/impact, Thordon elastomer bearing grades should be evaluated.



This photograph indicates that the ThorPlas bearing chamfers were too long and as the bearing was loaded in this area, not enough support was available for the material to take the load. Although the bearing cracked, it did not shatter and remained in one piece.

4. APPLICATION DESIGN

a) Application Analysis

Thordon Bearings Inc. has developed a software program for calculating the dimensions of the ThorPlas bearings.

This program greatly simplifies the dimensioning process. Using the Thordon Bearing Sizing Calculation Program is the preferred method of calculating dimensions for these bearings.

In order to perform an analysis for an application, all the appropriate information must be reviewed and correctly evaluated. The following parameters should be considered:

- Housing Size and Tolerance
- Shaft Diameter and Tolerance
- Length of Bearing
- Operating Temperatures
- Machine Shop Temperature
- Type of Lubrication
- Retention Method

Note: The recommended tolerance is H7 on the housing and h7 on the shaft. – See Appendix 1 on page 29 for complete metric and imperial shaft and housing tolerances for various sizes.

b) Interference

ThorPlas bearings are normally installed in a housing using an interference fit. The level of interference will depend on the design operating pressure of the bearing. Figure 9 (below) gives the pressure ranges and the appropriate interference calculation for each range.

Example:

Comparing interference values for a bearing to suit a 127 mm (5.000”) housing diameter at various pressure ranges:

- Low pressure application bearing, interference is: 0.30 mm (0.012”)
- Medium pressure application, interference is: 0.51 mm (0.020”)
- High pressure application, interference value is: 0.64 mm (0.025”)

The interference values presented are for minimum operating temperatures above -20°C (-4°F) and a machine shop ambient temperature of approximately 21°C (70°F). Increased interference values may be required for applications with lower operating temperatures, higher machine shop ambient temperatures and thin-walled bearing applications. A temperature adjustment chart is available from the Thordon Bearing Sizing Calculation Program. For those who are familiar with the ambient temperature adjustments required for Thordon elastomeric bearings (XL, SXL, COMPAC, etc.), it should be noted that ThorPlas materials have more stable thermal properties. For this reason, ambient temperature adjustments are less critical.

It can be installed using either a straight press fit technique or preferably by freeze fitting. For a high pressure application, with higher interference value, freezing of the bearing prior to press fitting is helpful. Significant line boring of the bearing I.D. after installation is not recommended because of the reduction this will have on the interference stress.

c) Bore Closure

Empirical data indicates ThorPlas bearings experience an I.D. reduction of approximately 110% of the diametrical interference. Therefore 110% of the interference should be considered in the machined bearing I.D. to allow for bore closure.

Example:

if a bearing has interference of 0.5 mm on the O.D., the bore closure allowance will be $0.5 \times 110\% = 0.55 \text{ mm}$

d) Running Clearance

The recommended running clearance for ThorPlas products is dependent on the type of service – see Figure 10a or 10b on page 14. For applications where the bearing is exposed to constant shaft rotation, the recommended running clearance is 0.15% x shaft diameter. For oscillatory applications, tighter clearances based on 0.10% x shaft diameter are permitted.

Please note that the running clearance for a ThorPlas bearing is NOT the same as the installed clearance. Thermal and water effects, although minimal, must still be taken into account.

TYPICAL INTERFERENCE AMOUNTS

Pressure	Bearing Pressure Range	Interference (Metric)	Interference (Imperial)
Low	Up to 300 psi (0 – 2 MPa)	Housing I.D. x 0.0020 + 0.05 mm	Housing I.D. x 0.0020 + 0.002”
Medium	300 – 1,500 psi (2 – 10 MPa)	Housing I.D. x 0.0034 + 0.05 mm	Housing I.D. x 0.0034 + 0.002”
High	1,500 – 6,500 psi (10 – 45 MPa)	Housing I.D. x 0.0045 + 0.05 mm	Housing I.D. x 0.0045 + 0.002”

Figure 9: Typical Interference Amounts

TYPICAL MINIMUM RUNNING CLEARANCE FOR THORPLAS (METRIC)

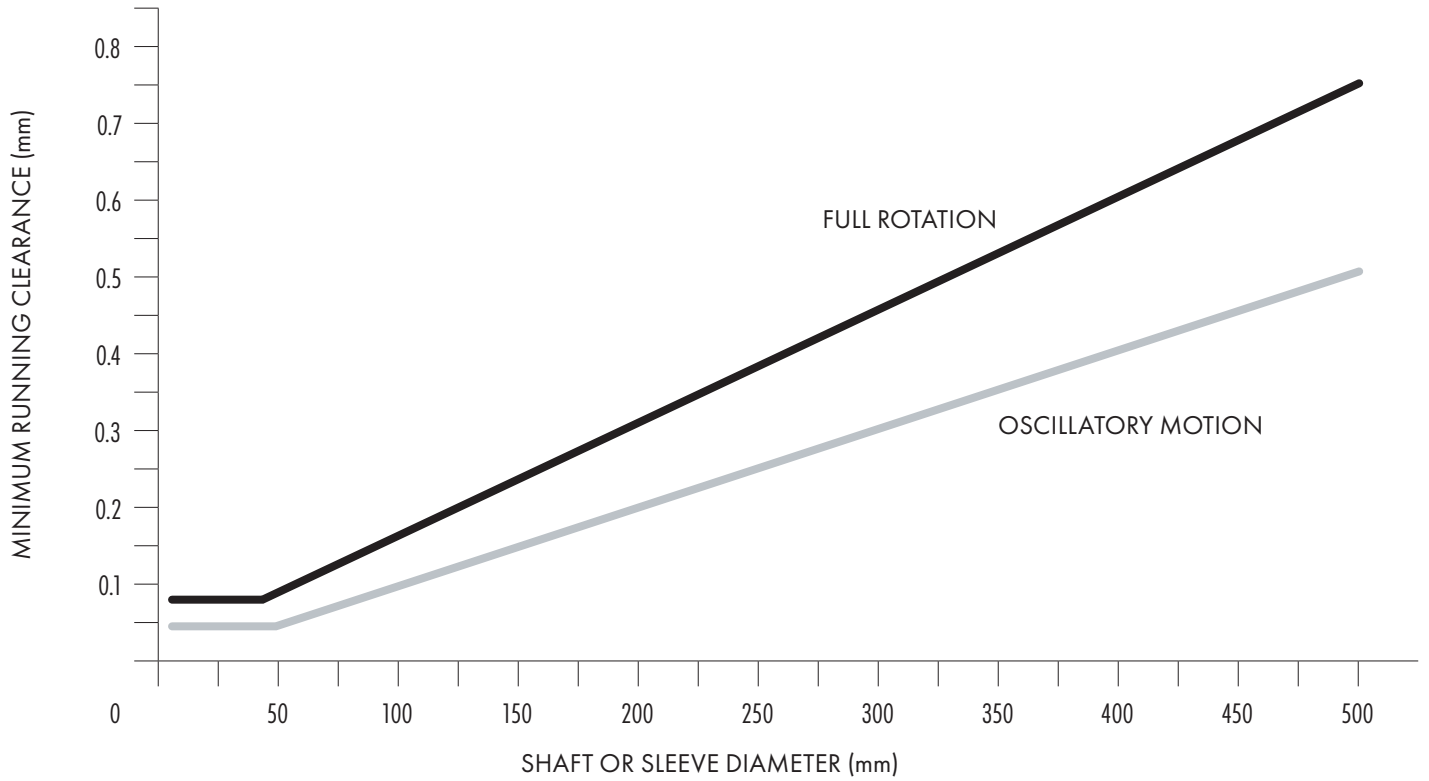

Figure 10a: Typical Minimum Running Clearance for ThorPlas (Metric)

TYPICAL MINIMUM RUNNING CLEARANCE FOR THORPLAS (IMPERIAL)

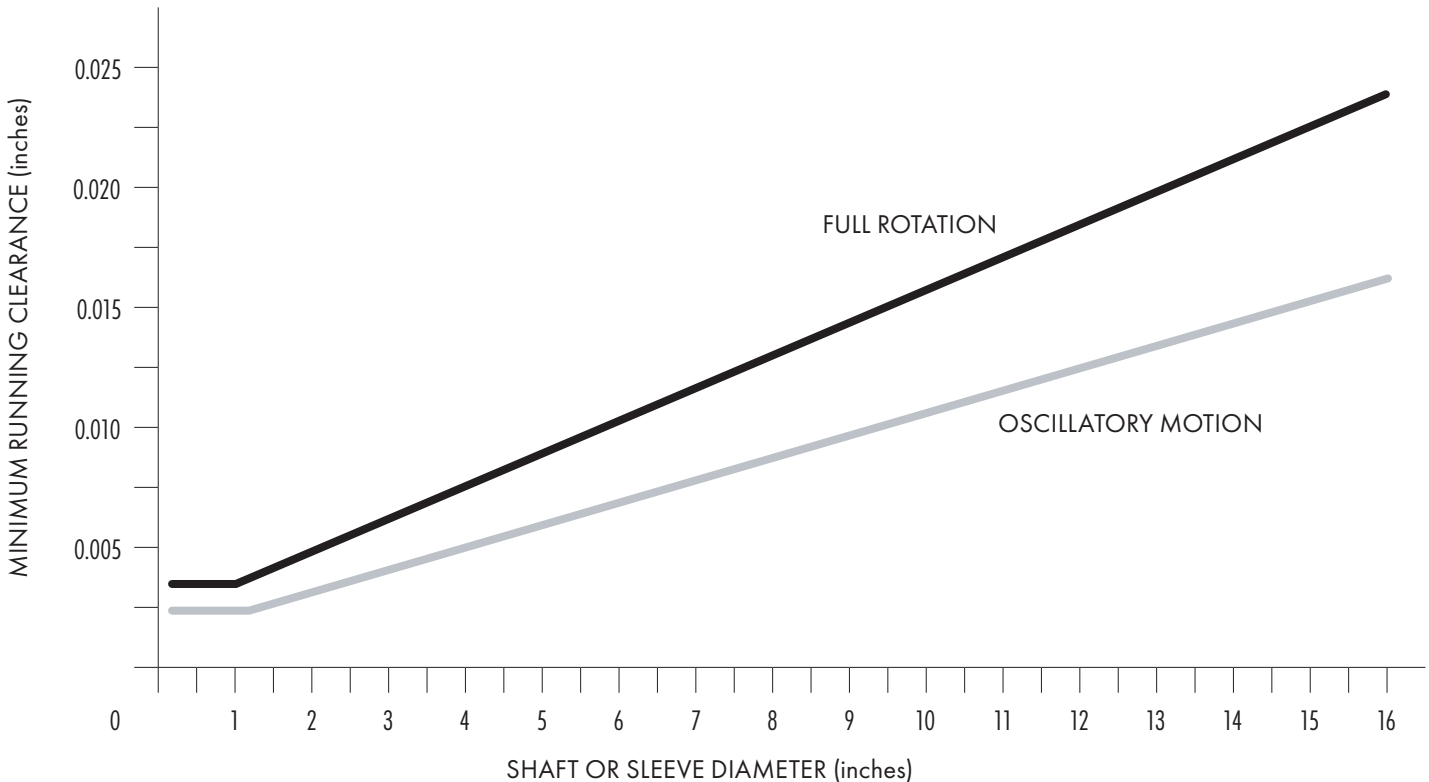

Figure 10b: Typical Minimum Running Clearance for ThorPlas (Imperial)

e) Absorption Allowance

The diametrical water absorption allowance for ThorPlas products is based upon the bearing wall thickness and it is typically calculated as 0.15% of the wall thickness. For a ThorPlas bearing with wall thickness of 12.7 mm (0.500"), the expected diametrical water absorption is 0.04 mm (0.0015"). This same absorption allowance should be used for bearings lubricated with oil or grease.

Water absorption also varies slightly with variations in maximum operating temperature. Figure 11 can be used as a guideline for manually calculating extra absorption allowances when the maximum operating temperature is higher than the standard 21°C (70°F) temperature.

f) Thermal Expansion Allowance

As with other Thordon grades, a thermal expansion allowance is used in the design of ThorPlas bearings when appropriate. The standard design temperature is 21°C (70°F). Thermal expansion should be considered for critical applications. The thermal expansion allowance is based upon the wall thickness (W.T.) of the bearing and the deviation between the standard design temperature and the maximum service temperature. The diametrical temperature allowance is calculated as follows:

Thermal Expansion Allowance (C_t)

$$C_t \text{ (diametrical)} = 2 \times \text{W.T.} \times \alpha \times (T_{\text{max}} - T_{\text{standard}})$$

where α = Thermal Coefficient of Expansion

For metric results:

$$C_t = 2 \times \text{W.T.} \times 4.6e^{-5} \times (T_{\text{max}} - T_{\text{standard}})$$

For imperial results:

$$C_t = 2 \times \text{W.T.} \times 2.5e^{-5} \times (T_{\text{max}} - T_{\text{standard}})$$

If ThorPlas bearings are machined at a temperature that is significantly different from 21°C (70°F), use the Thordon Bearing Sizing Calculation Program or contact Thordon Bearings to see if the thermal expansion allowance requires adjustment.

TYPICAL WATER ABSORPTION FACTOR (W.A.F.) FOR VARIOUS WATER TEMPERATURES

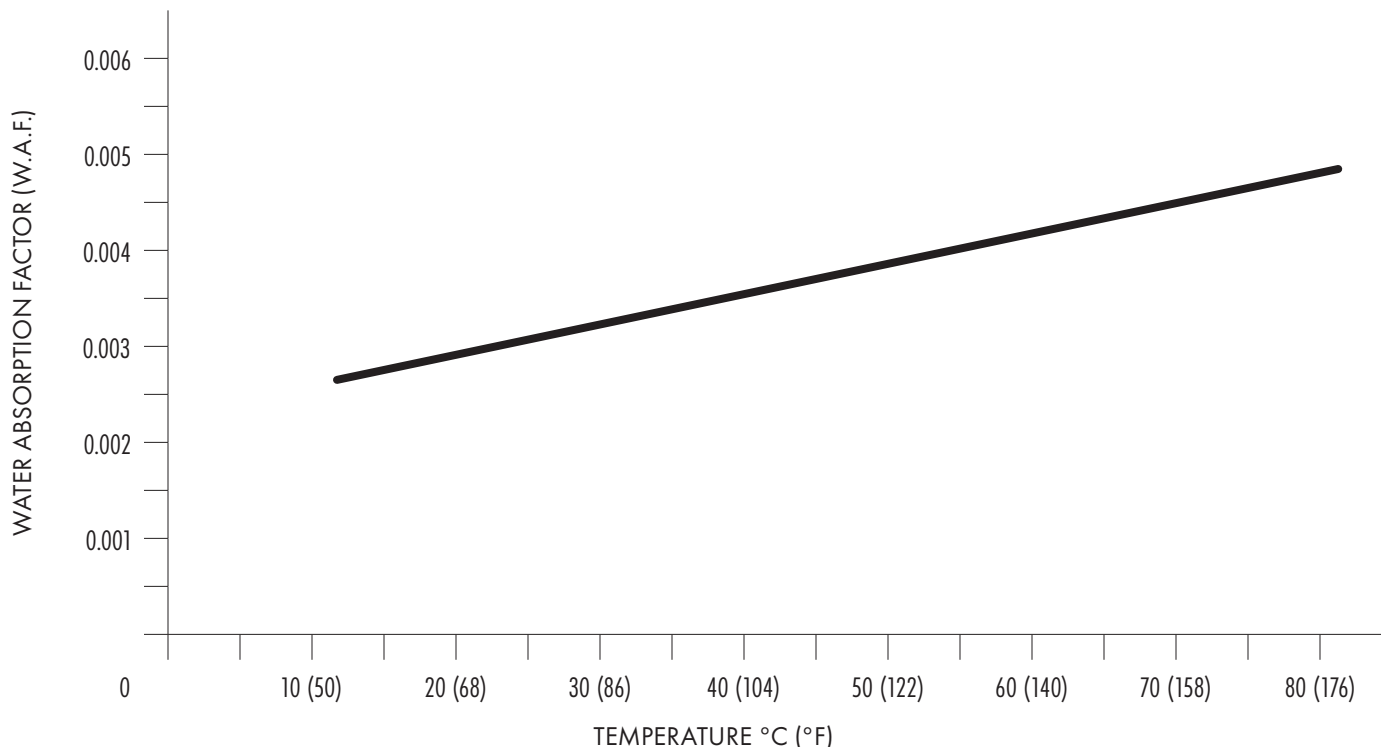

Figure 11: Typical Water Absorption Factor (W.A.F.) for Various Water Temperatures

g) Machining Tolerances

A - Bearing OD Machining Tolerances					
METRIC (mm)			IMPERIAL (inches)		
Bearing OD	Bearing Length	Tolerance on OD	Bearing OD	Bearing Length	Tolerance on OD
Up to 150	up to 100	+/-0.03	Up to 6.00"	up to 4.00"	+/-0.001
	above 100	+/-0.05		above 4.00"	+/-0.002
150 – 250	up to 150	+/-0.05	6.00" – 10.00"	up to 6.00"	+/-0.002
	150 – 250	+/-0.07		6.00" – 10.00"	+/-0.003
250 and up	maximum L/D of 1:1	+/-0.07	10.00" and up	maximum L/D of 1:1	+/-0.003

B - Bearing WALL THICKNESS Machining Tolerances					
METRIC (mm)			IMPERIAL (inches)		
Bearing OD	Bearing Length	Tolerance on WALL	Bearing OD	Bearing Length	Tolerance on WALL
Up to 150	up to 100	+0.00	Up to 6.00"	up to 4.00"	+0.000
		-0.03			-0.001
	above 100	+0.00		above 4.00"	+0.000
		-0.05			-0.002
150 – 250	up to 150	+0.00	6.00" – 10.00"	up to 6.00"	+0.000
		-0.05			-0.002
	150 – 250	+0.00		6.00" – 10.00"	+0.000
		-0.07			-0.003
250 and up	maximum L/D of 1:1	+0.00	10.00" and up	maximum L/D of 1:1	+0.000
		-0.07			-0.003

C - Bearing LENGTH Machining Tolerances			
METRIC (mm)		IMPERIAL (inches)	
Bearing Length	Tolerance on LENGTH	Bearing Length	Tolerance on LENGTH
Up to 150	+0.00	Up to 6.00"	+0.000
	-0.25		-0.010
150 – 250	+0.00	6.00" – 10.00"	+0.000
	-0.50		-0.020
250 and up	+0.00	10.00" and up	+0.000
	-1.00		-0.040

D - Washer Tolerances			
METRIC (mm)		IMPERIAL (inches)	
Bearing Dimension	Tolerance	Bearing Dimension	Tolerance
OD	+0.00	OD	+0.000
	-1.00		-0.040
ID	+1.00	ID	+0.040
	-0.00		-0.000
Thickness	+/-0.50	Thickness	+/-0.020

Figure 12: Machining Tolerances

h) Minimum Installed Clearance

The minimum installed clearance for a ThorPlas bearing is the sum of the following parameters:

Recommended Running Clearance
+
Thermal Expansion Allowance
+
Water Absorption Allowance

Minimum Installed Clearance is used as an important final check before putting the bearing into service. If the measured clearance after fitting is less than the Minimum Installed Clearance, then there is a high probability that the bearing may bind. The problem should be fixed before the bearing enters service. Do not expect the bearing to “conform” in service.

i) Machined Bearing O.D.

The machined bearing O.D. is the maximum housing diameter + interference as calculated in section 4.b).

The bearing O.D. machining tolerances for various sizes are shown in Figure 12-A on page 16.

j) Bearing I.D. and Wall Thickness

The machined bearing I.D. is calculated as follows:

Maximum Shaft Diameter
+
Bore Closure
+
Running Clearance
+
Thermal Expansion Allowance
+
Water Absorption Allowance

The bearing I.D. is best used as a reference only.

Machining the O.D. and wall thickness controls concentricity better. To determine the wall thickness value, use the calculated machined O.D. and the calculated machined I.D. and use the following equation:

$$\text{Machining Wall Thickness} = \frac{\text{Calculated O.D.} - \text{Calculated I.D.}}{2}$$

The machining tolerances for ThorPlas bearing wall thicknesses are presented in Figure 12-B on page 16.

k) Bearing Length

In addition to wall thickness, bearing length must be calculated with sufficient allowances for axial thermal expansion and water absorption.

k.1 Axial Thermal Expansion

Thermal Allowance =
Housing Length $\times \alpha \times (T_{\max} - T_{\text{standard}})$
where α = Thermal Coefficient of Expansion

For metric results:
= Housing Length $\times 4.6e^{-5} \times (T_{\max} - T_{\text{standard}})$

For imperial results:
= Housing Length $\times 2.5e^{-5} \times (T_{\max} - T_{\text{standard}})$

k.2 Axial Absorption Allowance

0.15% of housing length.

l) Bearing Retention

ThorPlas bearings operating at temperatures above 70°C (158°F) should be installed with anti-rotation devices as well as interference. Although interference is normally sufficient to prevent rotation of a bearing in its housing, at higher temperatures the risk of stress relaxation increases and the bearing could lose some of its interference. To prevent the bearing from turning under these circumstances, Thordon recommends that radial pins be fit through the housing wall into a hole in the bearing. The hole in the bearing should be fully through the wall, as shown in Figure 13 (below), so that the pin does not bottom out. Pins that are fit into blind holes can cause deformation on the inside diameter of the bearing.

The length of the pin should penetrate to minimum of half the bearing wall thickness. Consideration should be given to the wear of the bearing, so the pin does not contact the shaft. If two pins are fit, then place diametrically opposite each other.

m) Using the Thordon Bearing Sizing Calculation Program

A software program is available to calculate the sizing of ThorPlas bearings. It takes into account all of the factors covered in the application design section of this manual and greatly simplifies the calculation process. The program is available from your Thordon distributor or Thordon Bearings Inc.

The Thordon Bearing Sizing Calculation Program is, however, only as reliable as the information entered, care must be taken to ensure that all inputs are correct. Detailed help screens are available throughout the program if you have questions regarding a specific topic.

The Thordon Bearing Sizing Calculation Program is the preferred method for calculating dimensions of ThorPlas bearings. The following are examples of the Sizing Program used to calculate typical bearing dimensions.

Note: The values calculated from the Bearing Sizing Calculation Program may be slightly different than those calculated manually using this manual due to differences resulting from inaccuracies in reading values from the graphs, etc. In general, the bearing sizing program is more accurate than the manual calculation process.

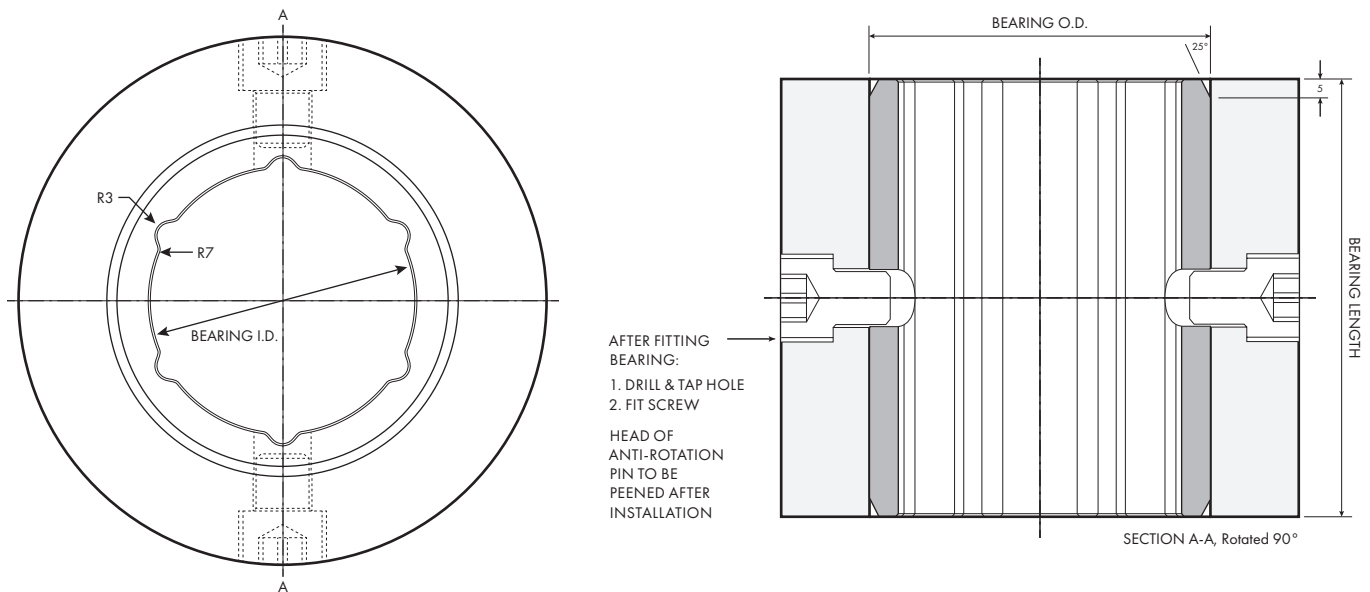

Figure 13: Bearing Retention with Anti-Rotation Pins

Samples Using Thordon Bearing Sizing Calculation Program

i) Metric Example – Wicket Gate Bearing

Given Data

1. Type of Service	Wicket Gate Bearing
2. Grade of Thordon	ThorPlas-Blue
3. Lubrication	Water
4. Type of Installation	Interference Fit
5. Shaft Diameter	150 mm +0.00/-0.04
6. Housing Diameter	175 mm +0.04/-0.00
7. Housing Length	100 mm
8. Operating Temperatures	Min. -2°C Max. 35°C
9. Machine Shop Ambient Temp.	21°C

Once the information above is entered, the Bearing Sizing Calculation Program gives the following results:

Thordon Bearing Sizing Calculation Program

No: V2017 Release 10
Print **Date:** 19-Jun-2019

Thordon Bearings Inc.

3225 Mainway, Burlington, Ontario, Canada L7M 1A6

Tel: 905-335-1440 www.thordonbearings.com

General Information

Thordon Distributor:
 Customer: ThorPlas-Blue Engineering Manual
 Project Reference:
 Calculated By:
 Checked By: Metric Calculations
 Comments:
 Drawing Number:
 MRP Number:

Data Sheet

-- ATTENTION --

Method of axial retention must be considered.

	Designed at 21 °C	Machined at 21 °C	
Machined Bearing Outside Diameter:	175.88	175.88 mm	+0.05, -0.05
Machined Bearing Inside Diameter:	151.14	151.14 mm	(For reference only)
Calculated Machined Bearing Length:	99.79	99.79 mm	+0.00, -0.25
Bearing Wall Thickness:	12.37	12.37 mm	+0.00, -0.05
Amount of Interference:	0.84 mm		
Bore Closure Factor:	1.100		
Bore Closure Amount:	0.92 mm		
Minimum Installed Diametrical Clearance (MIC):	0.22 mm		
Diametric Running Clearance:	0.15 mm		
Diametric Thermal Expansion:	0.03 mm		
Diametric Absorption Allowance:	0.04 mm		
Axial Thermal Expansion:	0.06 mm		
Axial Absorption Allowance:	0.15 mm		

Outside Diameter after dry ice cooling: 175.27 mm

Note: Forced press required after dry ice cooling; Never immerse a ThorPlas-Blue bearing in liquid nitrogen

Input Data

Dimension Scale: Metric (mm)
 Temperature Scale: Celsius
 Maximum Operating Temperature: 35 °C
 Minimum Operating Temperature: -2 °C
 Machine Shop Ambient Temperature: 21 °C

Maximum Shaft Diameter: 150 mm
 Maximum Housing Diameter: 175.04 mm
 Minimum Housing Diameter: 175 mm
 Housing Length: 100 mm

Type of Lubrication: Water
 Grade of Thordon Used: ThorPlas-Blue
 Type of Service: Hydro Wicket Gate & Linkage Bearings
 Type of Installation: Interference Freeze Fit

Load on Bearing: 0 kg
 Shaft RPM: 0

ii) Imperial Example - Wicket Gate Bearing

Given Data

1. Type of Service	Wicket Gate Bearing
2. Grade of Thordon	ThorPlas-Blue
3. Lubrication	Water
4. Type of Installation	Interference Fit
5. Shaft Diameter	6.500" + 0.000/-0.002"
6. Housing Diameter	7.500" + 0.002/-0.000"
7. Housing Length	6.000"
8. Operating Temperatures	Min. 28°F Max. 95°F
9. Machine Shop Ambient Temp.	70°F

Once the information above is entered, the Bearing Sizing Calculation Program gives the following results:

Thordon Bearing Sizing Calculation Program

Thordon Bearings Inc.

No: V2017 Release 10

3225 Mainway, Burlington, Ontario, Canada L7M 1A6

Print Date: 19-Jun-2019

Tel: 905-335-1440 www.thordonbearings.com

General Information

Thordon Distributor:
 Customer: ThorPlas-Blue Engineering Manual
 Project Reference:
 Calculated By:
 Checked By: Imperial Calculations
 Comments:
 Drawing Number:
 MRP Number:

Data Sheet

-- ATTENTION --

Method of axial retention must be considered.

	Designed at 69.8 °F	Machined at 70 °F	
Machined Bearing Outside Diameter:	7.538	7.538 in	+0.003, -0.003
Machined Bearing Inside Diameter:	6.548	6.549 in	(For reference only)
Calculated Machined Bearing Length:	5.987	5.987 in	+0.000, -0.020
Bearing Wall Thickness:	0.494	0.494 in	+0.000, -0.003
Amount of Interference:	0.036 in		
Bore Closure Factor:	1.100		
Bore Closure Amount:	0.039 in		
Minimum Installed Diametrical Clearance (MIC):	0.009 in		
Diametric Running Clearance:	0.007 in		
Diametric Thermal Expansion:	0.001 in		
Diametric Absorption Allowance:	0.002 in		
Axial Thermal Expansion:	0.004 in		
Axial Absorption Allowance:	0.009 in		

Outside Diameter after dry ice cooling: 7.511 in

Note: Forced press required after dry ice cooling; Never immerse a ThorPlas-Blue bearing in liquid nitrogen

Input Data

Dimension Scale: Imperial (in)
 Temperature Scale: Fahrenheit
 Maximum Operating Temperature: 95 °F
 Minimum Operating Temperature: 28 °F
 Machine Shop Ambient Temperature: 70 °F

Maximum Shaft Diameter: 6.500 in
 Maximum Housing Diameter: 7.502 in
 Minimum Housing Diameter: 7.500 in
 Housing Length: 6.000 in

Type of Lubrication: Water
 Grade of Thordon Used: ThorPlas-Blue
 Type of Service: Hydro Wicket Gate & Linkage Bearings
 Type of Installation: Interference Freeze Fit

Load on Bearing: 0 lb
 Shaft RPM: 0

n) Step-by-Step Manual Calculations

i) Metric Example

Given Data

1. Type of Service	Wicket Gate Bearing
2. Grade of Thordon	ThorPlas-Blue
3. Lubrication	Water
4. Type of Installation	Interference Fit
5. Shaft Diameter	150 mm +0.00/-0.04
6. Housing Diameter	175 mm +0.04/-0.00
7. Housing Length	100 mm
8. Maximum Ambient Temperature	35°C
9. Maximum Bearing Pressure	>25MPa
10. Lubrication	Water

Step 1 - Interference

Interference from Figure 9

$$\begin{aligned} &= 0.05 + 0.0045 \times \text{Housing Diameter} \\ &= 0.05 + 0.0045 \times 175 \\ &= 0.84\text{mm} \end{aligned}$$

Step 2 - Bearing O.D.

$$\begin{aligned} &= \text{maximum housing diameter} + \text{interference} \\ &= 175.04 + 0.84 \\ &= 175.88\text{mm} \\ &\text{With machining tolerance } 175.88 \text{ mm } +/-0.05\text{mm} \end{aligned}$$

Step 3 - Bore Closure

The bore closure effect on the bearing I.D. is 110% of the interference.

$$\text{Bore closure} = .84 \times 1.10 = 0.92 \text{ mm}$$

Step 4 - Running Clearance

$$\begin{aligned} &\text{Running clearance for oscillating motion} \\ &= 0.10\% \text{ of shaft diameter} \\ &= 0.001 \times 150 \\ &= 0.15\text{mm} \end{aligned}$$

Step 5 - Thermal Expansion Allowance

$$\begin{aligned} &= 2 \times \text{W.T.} \times \alpha \times (T_{\text{max}} - 21^\circ\text{C}) \\ &= 2 \times 12.5 \times 4.6e^{-5} \times (35 - 21) \\ &= 0.02 \text{ mm } 0.03 \text{ mm} \\ &(\text{minimal allowance of } 0.03 \text{ mm used for safety margin}) \end{aligned}$$

Step 6 - Water Absorption Allowance

$$\begin{aligned} &0.15\% \text{ of wall thickness} \\ &= 2 \times 0.0015 \times 12.5 \\ &= 0.0375 \text{ mm or approx. } 0.04\text{mm} \end{aligned}$$

Step 7 - Machined Bearing I.D.

The machined bearing I.D. is the shaft diameter plus the sum of steps 3 – 6
(bore closure + running clearance + thermal expansion allowance + water absorption allowance)

$$\begin{aligned} &= 150 + 0.92 + 0.15 + 0.03 + 0.04 \\ &= 151.14 \text{ mm (for reference only)} \end{aligned}$$

Step 8 - Minimum Installed Clearance

Minimum Installed Clearance (for checking)

$$\begin{aligned} &= \text{running clearance} \\ &+ \text{thermal expansion allowance} \\ &+ \text{water absorption allowance} \\ &= .15 + 0.03 + 0.04 \\ &= 0.22 \text{ mm} \end{aligned}$$

Step 9 - Bearing Length

In calculating the length of a ThorPlas-Blue bearing, allowances must be made for axial thermal expansion and water absorption.

$$\begin{aligned} &\text{Axial thermal expansion} \\ &= \text{housing length} \\ &\times \text{coefficient of thermal expansion} \\ &\times \text{temperature difference} \\ &= 100 \times 4.6e^{-5} \times (35 - 21) \\ &= 0.06 \text{ mm} \end{aligned}$$

$$\begin{aligned} &\text{Axial absorption allowance is } 0.15\% \text{ of housing length} \\ &= 100 \times 0.0015 \\ &= 0.15 \text{ mm} \end{aligned}$$

$$\begin{aligned} &\text{Machined bearing length} \\ &= \text{housing length} \\ &- \text{axial thermal expansion allowance} \\ &- \text{axial absorption allowance} \\ &= 100 - 0.06 - 0.15 \\ &= 99.79 \text{ mm} \end{aligned}$$

$$\begin{aligned} &\text{With machining tolerance} \\ &= 99.79 \text{ mm } + 0.00 / -0.25 \text{ mm} \end{aligned}$$

Note: Calculation Program uses latest design parameters and takes precedence over manually calculated results.

ii) Imperial Example

Given Data

1. Type of Service	Wicket Gate Bearing
2. Grade of Thordon	ThorPlas-Blue
3. Lubrication	Water
4. Type of Installation	Interference Fit
5. Shaft Diameter	6.500" + 0.000/-0.002"
6. Housing Diameter	7.500" + 0.002/-0.000"
7. Housing Length	6.000"
8. Maximum Ambient Temperature	95°F
9. Maximum Bearing Pressure	> 2000 psi
10. Lubrication	Water

Step 1 - Interference

Interference from Figure 9
= 0.002" + 0.0045" x housing diameter
= 0.002" + 0.0045" x 7.5"
= 0.036"

Bearing O.D.

Step 2 - Bearing O.D.

Bearing O.D. = maximum housing diameter + interference
= 7.502" + 0.036"
= 7.538"

With machining tolerance = 7.538" +/-0.003"

Step 3 - Bore Closure

The bore closure effect on the bearing I.D. is 110% of the interference.

Bore closure = 0.036 x 1.10 = 0.039"

Step 4 - Running Clearance

Running clearance for oscillating motion = 0.10% of shaft diameter
= 0.001 x 6.5"
= 0.0065" or approx. 0.007"

Step 5 - Thermal Expansion Allowance

= 2 x W.T. x α x (T_{max} - 70°F)
= 2 x .5 x 2.5e⁻⁵ x (95 - 70)
= 0.001"

Step 6 - Water Absorption Allowance

The water absorption allowance is 0.15% of wall thickness
= 2 x 0.0015 x 0.5
= 0.002"

Step 7 - Machined Bearing I.D.

The machined bearing I.D. is the shaft diameter plus the sum of steps 3 - 6
(bore closure + running clearance + thermal expansion allowance + water absorption allowance)
= 6.5" + 0.039" + 0.007" + 0.001" + 0.002"
= 6.549" (for reference only)

Step 8 - Minimum Installed Clearance

Minimum Installed Clearance
= running clearance
+ thermal expansion allowance
+ water absorption allowance
= 0.007" + 0.001" + 0.002"
= 0.010"

Step 9 - Bearing Length

In calculating the length of a ThorPlas bearing, allowances must be made for axial thermal expansion and water absorption.

Axial thermal expansion
= housing length
x coefficient of thermal expansion
x temperature difference
= 6" x 2.5e⁻⁵ x (95 - 70)
= 0.004"

Axial absorption allowance is 0.15% of housing length
= 6 x 0.0015
= 0.009"

Machined bearing length
= housing length
- axial thermal expansion allowance
- axial absorption allowance
= 6" - 0.004" - 0.009"
= 5.987"

With machining tolerance
= 5.987" + 0.000 / -0.020"

Note: Calculation Program uses latest design parameters and takes precedence over manually calculated results.

5. MACHINING INSTRUCTIONS

a) General Raw Material Cutting

ThorPlas materials are easily cut from tube or rod using a bandsaw. Depending on bearing sizes, allow for 25 – 40 mm (0.984" – 1.575") of material length for chucking and holding the part for machining.

Guidelines for safe raw material cutting:

- Provide good support to the raw material tube or rod without over-clamping (to avoid cracking). Maximum recommended bandsaw clamping pressure is 1.38 MPa (200 psi).
- Use a Bi-metal bandsaw blade with 10 – 14 TPI. (Wikus Primar M42 1.062" x 0.035" thick).
- Coolant is not required when cutting ThorPlas bearings.
- Ensure cutting is fully supported to avoid cracking.
- If an audible "ting" is heard during the cutting operation, carefully inspect the raw material for possible damage.

Maximum recommended bandsaw blade surface speed per minute is 91.4 – 106.7 SMPM (300 – 350 SFPM). Ensure bandsaw blade is at full speed before starting to feed.

Maximum recommended cutting feed rate is 235 mm per minute (9.25 inch per minute).

b) General Machining

ThorPlas materials are easily machined to fine tolerances. The material can be milled, sawed, planed, drilled, tapped and threaded. Depending on bearing sizes, allow for 25 – 40 mm (0.984" – 1.575") of material length for chucking and holding the part for machining.

Guidelines for safe machining:

- Use sharp tools (carbide grade)
- Provide good support to the part without over-clamping (to avoid cracking)
- Avoid sharp corners/edges
- Adequate material cuttings removal during machining
- Coolants may be considered for drilling holes

Typical cutting speeds for the ThorPlas materials are between 150 – 300 m/min (492 – 985 fpm).

TYPICAL CUTTING SPEEDS FOR MACHINING THORPLAS

Diameter	RPM
200 mm (7.874")	350
300 mm (11.811")	300
400 mm (15.750")	200
500 mm (19.685")	150
600 mm (23.622")	100

Figure 14: Typical Cutting Speeds for Machining ThorPlas

Cutting Feeds used for rough turning are 0.38 – 0.5 mm (0.015" – 0.020") per revolution. For finish turning, 0.12 – 0.25 mm (0.005" – 0.010") per revolution are recommended.

As mentioned, fine tolerances can be achieved for ThorPlas bearings, as shown earlier in Section 4(g) on page 16.

c) Groove Cutting

Water grooves, when required, are normally broached using custom-made cutting tools to produce the dimensions given in Figures 6 and 7 in Section 3(e) on page 10. A minimum of 40 mm (1.575") chucking is needed for turning the I.D. length 18 – 20 mm (0.709" – 0.787") longer to allow for removal of broach cuttings. Because you are broaching the material, your broach length should be 3 mm (0.118") shorter than your I.D. length – so if cuttings get wrapped up, you still have enough groove length to part off the bearing to required length.

The following custom-made tool bits can be ordered from Thordon Bearings or your Thordon distributor using the appropriate Part Numbers:

F99TB003: Tool bit with profile to machine 3 mm (0.118") radius groove with 7 mm (0.276") radius edge

F99TB004: Tool bit with profile to machine 4 mm (0.157") radius groove with 7 mm (0.276") radius edge

d) Chamfers

Chamfers should be machined on the O.D. of each end of the bearing to facilitate installation following guidelines in Figure 14 (left) and the dimensions in Figure 15 (below).

DIMENSIONS FOR MACHINING CHAMFERS

METRIC:

Bearing Length	Chamfer Detail
Below 25 mm	1.5 mm x 25°
25 – 100 mm	3.0 mm x 25°
Over 100 mm	5.0 mm x 25°

IMPERIAL:

Bearing Length	Chamfer Detail
Below 1 inch	1/16" x 25°
1 – 4 inches	1/8" x 25°
Over 4 inches	1/4" x 25°

Figure 15: Dimensions for Machining Chamfers

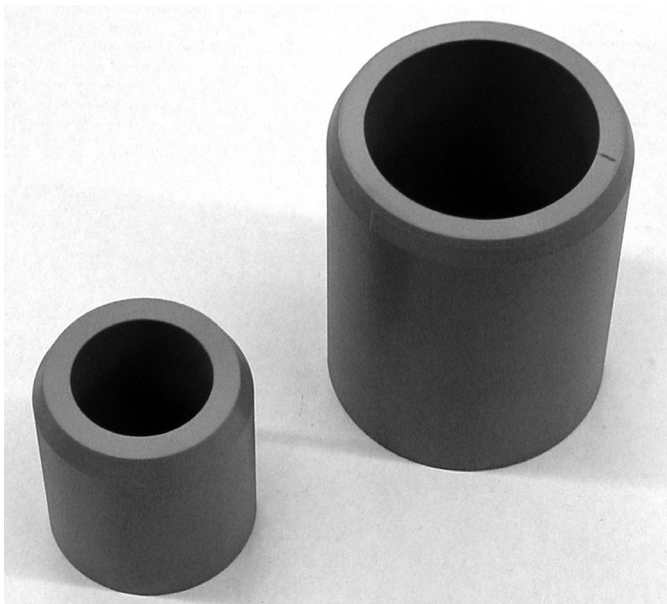

Figure 16: Chamfer on ThorPlas-Blue bearings

e) Step-By-Step Machining Process

Steps 1 through 8 illustrate a typical machining process for the ThorPlas material in a standard lathe.

Step 1.

Cut part allowing extra length for chucking, parting off and facing. Typically chucking lengths of 25 mm (1") are sufficient for bearings up to 152 mm (6") O.D.

For large parts - O.D. more than 152 mm (6"), thin wall bearings and/or for parts with tighter than standard tolerances, an internal metal chucking ring is always required to support the bearing in the chuck jaws.

Step 2a.

Set the part in the chuck jaws as shown below. These figures show a piece with sizes of 76.2 mm O.D. x 25 mm I.D. (3" x 1") squared in the chuck using a three-jaw configuration. Use light to moderate clamping forces. Do not over clamp as this can cause stresses in the material resulting in cracking.

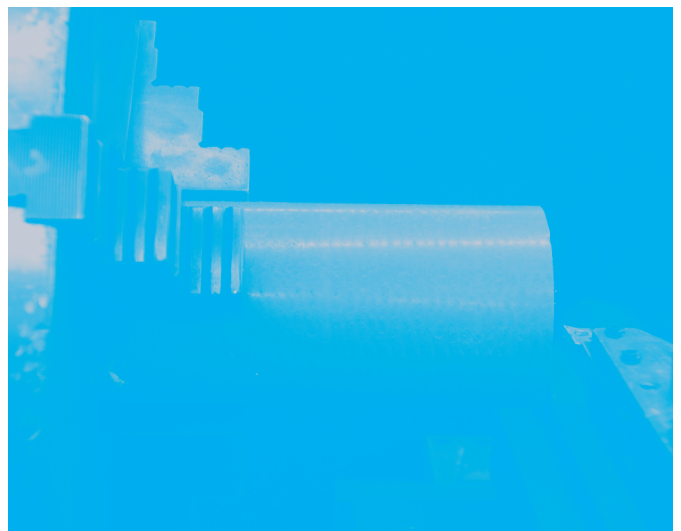

Step 2b.

For parts needing an internal metal chucking ring, machine slightly the O.D. to clean uneven surfaces and machine the I.D. so that the chucking ring has a slight interference with the ThorPlas material - interference of 0.03 mm (0.001"). Typical thickness of chucking rings varies from 12 mm (0.5") for small parts to as high as 25 mm (1.0") for parts with O.D. values more than 250 mm (10"). Figures below show a ThorPlas-Blue bearing, size of 152 mm (6.0") O.D., where a chucking ring is used for extra support.



Step 3.

Sharp and smooth tool bits will ensure the best finish when machining the ThorPlas materials. The photo below illustrates the tools used to machine ThorPlas bearings– the bit on the left is used for machining the I.D. while the bit on the right is used for the O.D.

Note: Cutting feeds for rough turning are 0.38 – 0.50 mm (0.015" – 0.020") per revolution. For finish turning, 0.12 – 0.25 mm (0.005" – 0.010") feeds are recommended.

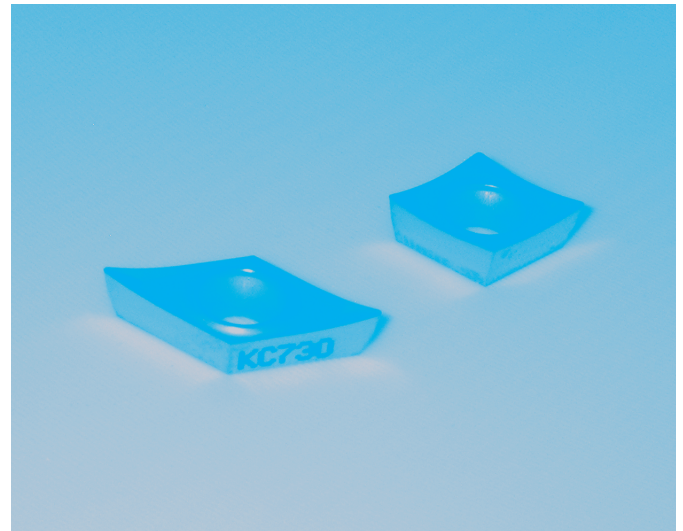

Step 4.

Machine the bearing O.D. using the appropriate tool.



Step 5.

Proceed to machine the bearing wall thickness using the tool bit and the boring bar. Clearing of chips or shavings from bearing I.D. is important to reduce heat buildup and to obtain desired tolerances.

Step 6.

If broaching the bearing, ensure the bearing length has 50 mm (2") chucking allowance to allow enough space for cuttings/streamers.

Broach the grooves using the custom-made cutting tool shown below.



Step 7.

Part bearing to length using the parting tool. Support the bearing as the cut is made so that it does not fall. As shown below, fine streamers are collected after machining the ThorPlas materials.



Step 8.

Chamfers can be machined or routed on the end of the bearings to ease installation. Use Figure 15 on page 24 for proper dimension of chamfers based on bearing size.

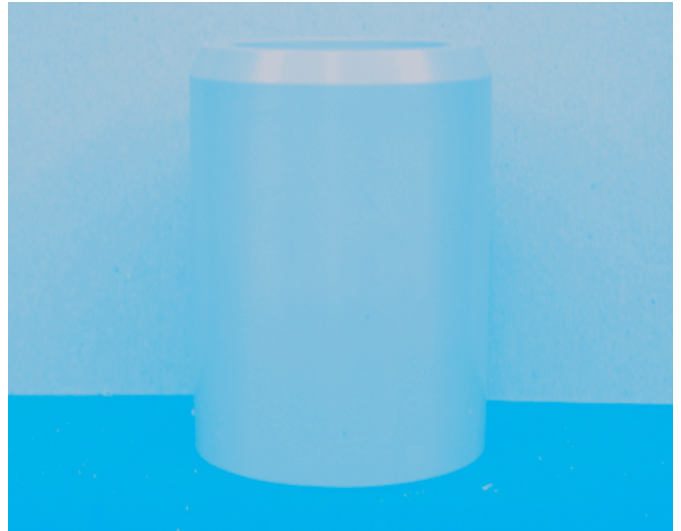

f) Machining Tolerances

Machining Tolerances found in Section 4(g) on page 16.

6. INSTALLATION GUIDELINES

a) Freeze Fit Installations

As mentioned previously, the preferred method of fitting the ThorPlas family of bearings is using an interference fit.

A combination of freeze fitting and press in installation is recommended for bearings with high interference.

Cooling of the bearings can be achieved by placing them in a freezer or using dry ice.

CAUTION: Use of liquid nitrogen or significant quantities of dry ice in closed or poorly ventilated areas should be avoided. The boiled off gases tend to displace the existing oxygen and can be fatal.

Using Liquid Nitrogen

Liquid nitrogen may be used, but never immerse ThorPlas bearings directly into the liquid nitrogen as cracking of the bearing can occur as the bearing warms up. Suspend the bearing in the cold liquid nitrogen vapor for typically 30 minutes. (As shown below)

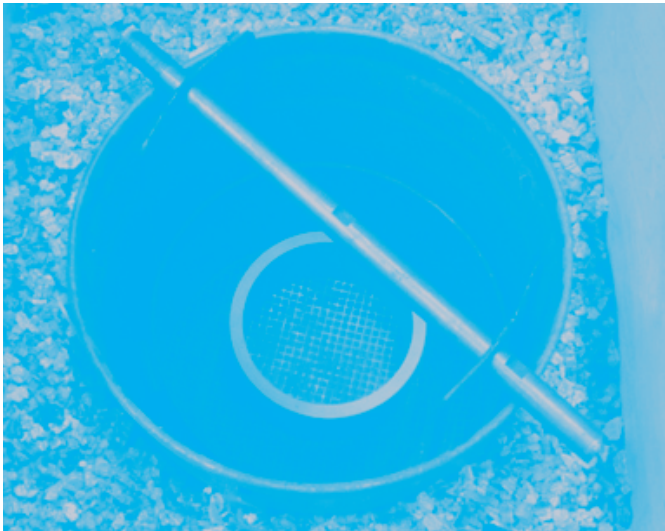

See **b) Press Fit Installations** on next page.

Using Dry Ice

Cooling of the bearings can be achieved by placing them directly in dry ice. The combination of dry ice freezing and press-in assists in the installation of bearings with a high level of interference.

When using dry ice, typically allow at least 1-2 hours of cooling for sufficient reduction of the bearing O.D. for installation. Measure the bearing O.D. to establish the amount of cooling achieved before proceeding with the press in installation. Lead-in chamfers at the top of the housing (if not already present) and on one end of the bearing are recommended to assist in the installation of the bearings – see Figure 17 in following section.

Note: For optimal performance, the following should be considered when evaluating the condition of the bearing housing:

- i) The surface finish on the housing I.D. is not critical as there is no movement of the bearing O.D. after installation. However for best practices, the finish must not be too coarse. Remove any burrs or sharp edges.*
- ii) Machine the housing I.D. to an H7 tolerance or better for proper support along the whole ThorPlas bearing length.*

b) Press Fit Installations

ThorPlas bearings may be easily press fit into housings where the L/D ratio < 1.5.

A 25° chamfer on the O.D. will facilitate installation when using this method. A combination of cooling and press fit is adequate for most installations. See steps 1 through 3 (right) for illustrations. For situations where the L/D ratio is greater than 2, consult Thordon Bearings for recommendations.

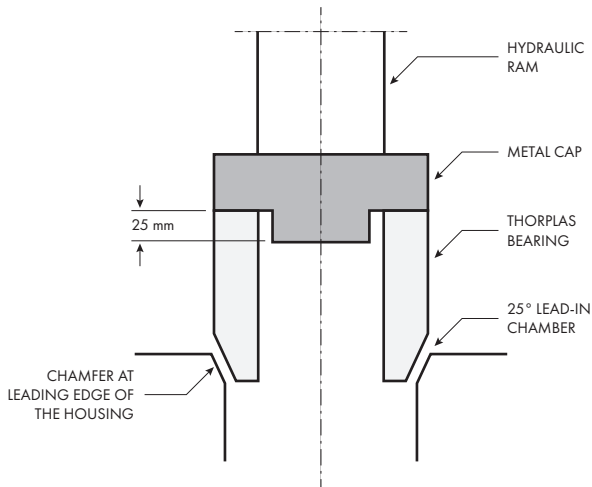

Figure 17: Press in set up for ThorPlas bearings

Note: Caution should be taken, as direct impact on the material may cause fracture.

Press Force Required

The force required to press a ThorPlas bearing into a housing without cooling the bearing would be:

$$F(\text{kg}) = \frac{\text{interference (mm)} \times \text{wall thickness (mm)} \times \text{length (mm)} \times 200}{\text{housing bore (mm)}}$$

$$F(\text{N}) = \frac{\text{interference (mm)} \times \text{wall thickness (mm)} \times \text{length (mm)} \times 2,000}{\text{housing bore (mm)}}$$

$$F(\text{tons}) = \frac{\text{interference (in)} \times \text{wall thickness (in)} \times \text{length (in)} \times 140}{\text{housing bore (in)}}$$

Note: For thin wall bearings and long bearings with L/D exceeding 2:1, freeze fitting is a preferred method to eliminate risk of buckling. When in doubt, please consult with Thordon Bearings Inc.

1) Set up of bearing for press fit and initial push into housing.

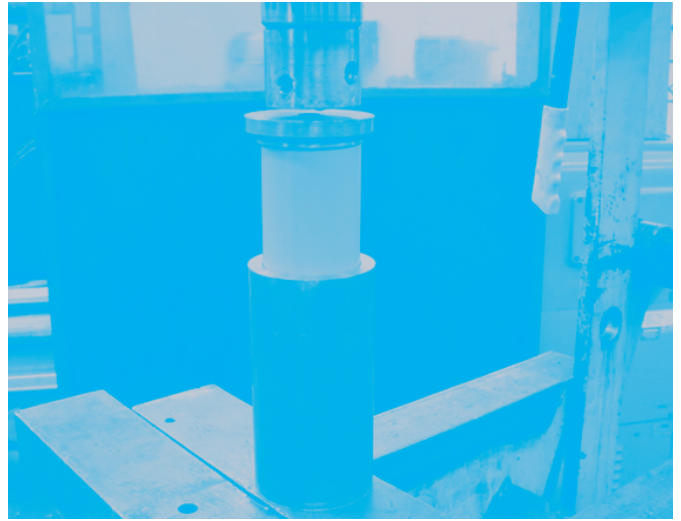

2) 75% of bearing length inside the housing.



3) Bearing in housing.



Mechanical Retention

When deemed necessary, radial pins or other mechanical means (consult Thordon Bearings) may be used to prevent the bearing from rotating in the housing.

APPENDIX 1.

Shaft and Housing Tolerances (ISO Tolerances, reference ISO 286-2)

METRIC

Shaft Tolerances h7			Housing Tolerances H7		
Basic Sizes (mm)		Tolerance value in mm	Basic Sizes		Tolerance value in mm
Above	Up to and including		Above	Up to and including	
0	3	+0.000 -0.010	0	3	+0.010 -0.000
3	6	+0.000 -0.012	3	6	+0.012 -0.000
6	10	+0.000 -0.015	6	10	+0.015 -0.000
10	18	+0.000 -0.018	10	18	+0.018 -0.000
18	30	+0.000 -0.021	18	30	+0.021 -0.000
30	50	+0.000 -0.025	30	50	+0.025 -0.000
50	80	+0.000 -0.030	50	80	+0.030 -0.000
80	120	+0.000 -0.035	80	120	+0.035 -0.000
120	180	+0.000 -0.040	120	180	+0.040 -0.000
180	250	+0.000 -0.046	180	250	+0.046 -0.000
250	315	+0.000 -0.052	250	315	+0.052 -0.000
315	400	+0.000 -0.057	315	400	+0.057 -0.000
400	500	+0.000 -0.063	400	500	+0.063 -0.000
500	630	+0.000 -0.070	500	630	+0.070 -0.000
630	800	+0.000 -0.080	630	800	+0.080 -0.000
800	1000	+0.000 -0.090	800	1000	+0.090 -0.000
1000	1250	+0.000 -0.105	1000	1250	+0.105 -0.000
1250	1600	+0.000 -0.125	1250	1600	+0.125 -0.000
1600	2000	+0.000 -0.150	1600	2000	+0.150 -0.000
2000	2500	+0.000 -0.175	2000	2500	+0.175 -0.000
2500	3150	+0.000 -0.210	2500	3150	+0.210 -0.000

IMPERIAL

Shaft Tolerances h7			Housing Tolerances H7		
Basic Sizes (inches)		Tolerance Value in inches	Basic Sizes (inches)		Tolerance Value in inches
Above	Up to and including		Above	Up to and including	
0	0.118	+0.000 -0.0004	0	0.118	+0.0004 -0.000
0.118	0.236	+0.000 -0.001	0.118	0.236	+0.001 -0.000
0.236	0.394	+0.000 -0.001	0.236	0.394	+0.001 -0.000
0.394	0.709	+0.000 -0.001	0.394	0.709	+0.001 -0.000
0.709	1.181	+0.000 -0.001	0.709	1.181	+0.001 -0.000
1.181	1.969	+0.000 -0.001	1.181	1.969	+0.001 -0.000
1.969	3.150	+0.000 -0.001	1.969	3.150	+0.001 -0.000
3.150	4.724	+0.000 -0.002	3.150	4.724	+0.002 -0.000
4.724	7.087	+0.000 -0.002	4.724	7.087	+0.002 -0.000
7.087	9.843	+0.000 -0.002	7.087	9.843	+0.002 -0.000
9.843	12.402	+0.000 -0.002	9.843	12.402	+0.002 -0.000
12.402	15.748	+0.000 -0.002	12.402	15.748	+0.002 -0.000
15.748	19.685	+0.000 -0.003	15.748	19.685	+0.003 -0.000
19.685	24.803	+0.000 -0.003	19.685	24.803	+0.003 -0.000
24.803	31.496	+0.000 -0.003	24.803	31.496	+0.003 -0.000
31.496	39.370	+0.000 -0.004	31.496	39.370	+0.004 -0.000
39.370	49.213	+0.000 -0.004	39.370	49.213	+0.004 -0.000
49.213	62.992	+0.000 -0.005	49.213	62.992	+0.005 -0.000
62.992	78.740	+0.000 -0.006	62.992	78.740	+0.006 -0.000
78.740	98.425	+0.000 -0.007	78.740	98.425	+0.007 -0.000
98.425	124.016	+0.000 -0.008	98.425	124.016	+0.008 -0.000

LIMITED WARRANTY AND LIMITATION OF LIABILITY FOR THORDON BEARINGS INC. ('TBI')

- a. **Basic Terms.** TBI provides a limited warranty on the Goods of its own manufacture sold by it to the Buyer thereof, against defects of material and workmanship (the "Limited Warranty").
- b. **Coverage.** This Limited Warranty covers the repair or replacement or the refund of the purchase price, as TBI may elect, of any defective products regarding which, upon discovery of the defect, the Buyer has given immediate written notice. TBI does NOT warrant the merchantability of its product and does NOT make any warranty express or implied other than the warranty contained herein.
- c. **Third Party Products.** Accessories, equipment and parts not manufactured by TBI are warranted or otherwise guaranteed only to the extent and in the manner warranted or guaranteed to TBI by the actual manufacturer, and then only to the extent TBI is able to enforce such warranty or guarantee.
- d. **Limited Liability.** TBI's liability for any and all claims, damages, losses and injuries arising out of or relating to its performance or breach of any contract of sale of goods and the manufacture, sale delivery, re-sale, repair, or use of any goods, shall NOT exceed the agreed price of such Goods. The Buyer's remedy shall be at TBI's option, the replacement or repair of the Goods. This shall be the Buyer's sole, exclusive and only remedy against TBI.
- IN NO EVENT SHALL TBI BE LIABLE FOR INCIDENTAL, SPECIAL OR CONSEQUENTIAL DAMAGES, INCLUDING BUT NOT LIMITED TO LOSS OF PROFITS, BUSINESS, GOODWILL, INCURRING OF MACHINERY DOWNTIME, DESTRUCTION OR LOSS OF ANY CAPITAL GOODS, LIABILITY FOR PERSONAL INJURY, DEATH, PROPERTY DAMAGE AND ANY OTHER TYPE OF DAMAGES WHETHER SIMILAR TO OR DIFFERENT FROM THIS LISTING.
- e. **Latent Defects.** In cases of defects in materials or workmanship or defects arising from the selection of material or processes of manufacturer, such defects must be apparent in the Goods within three (3) months, after delivery and acceptance of the Goods to the Buyer.
- f. **Exclusions.** TBI shall, as to each aforesaid defect, be relieved of all obligations and liability under this Limited Warranty if:
1. The Goods are operated with any accessory, equipment or part not specifically approved by TBI and not manufactured by TBI or to TBI's design and specifications, unless the Buyer furnishes reasonable evidence that such installation was not a cause of the defect; provided, that this provision shall not apply to any accessory, equipment or part, the use of which does not affect the safety of the Goods;
 2. The Goods shall not be operated or maintained in accordance with TBI's written instructions as delivered to the Buyer, at any time or from time to time, unless the Buyer furnishes reasonable evidence that such operation or maintenance was not a cause of the defect;
 3. The Goods shall not be operated or maintained under normal industry use, unless the Buyer furnishes reasonable evidence that such operation was not a cause of the defect;
 4. The Goods shall have been repaired, altered or modified without TBI's written approval or, if the Goods shall have been operated subsequent to its involvement in an accident or breakdown, unless the Buyer furnishes reasonable evidence that such repair, alteration, modification, operation, accident or breakdown was not a cause of the defect; provided, however, that this limitation insofar as it relates to repairs, accidents and breakdowns, shall NOT be applicable to routine repairs or replacements or minor accidents or minor breakdowns which normally occur in the operation of a machine, if such repairs or replacements are made with suitable materials and according to standard practice and engineering;
 5. The Buyer does not submit reasonable proof to TBI that the defect is due to a material embraced within TBI's Limited Warranty hereunder.
- g. **Warranty Term.** This Limited Warranty made by TBI contained in these Terms and Conditions, or contained in any document given in order to carry out the transactions contemplated hereby, shall continue in full force and effect for the benefit of the Buyer, save and except, no warranty claim may be made or brought by the Buyer after the date which is twelve (12) months following delivery and acceptance of the Goods pursuant to this Contract.
- h. **Expiration and Release.** After the expiration of this Limited Warranty's period of time, as aforesaid, TBI shall be released from all obligations and liabilities in respect of such warranty made by TBI and contained in this Contract or in any document given in order to carry out the transactions contemplated hereby.

CUSTOMER FOCUSED TO SUPPORT YOUR IMMEDIATE AND FUTURE NEEDS

Supply and Service

Geared to provide quick response to customer needs, Thordon Bearings understands the importance of fast delivery and reduced down time. Thordon marine and industrial bearings can be designed, produced to the exact requirements of the customer and shipped quickly.

Distribution

With Thordon bearings specified all around the world, an extensive distribution network has been established in over 100 countries. Inventories of common bearing sizes are stocked by local Thordon Distributors and are backed up by large regional and head office Thordon stocks.

Application Engineering

Thordon Bearing's engineers work closely with customers to provide innovative bearing system designs that meet or exceed the technical requirements of the application.

Manufacturing

Thordon's modern polymer processing facility is staffed with experienced and dedicated employees. Bearings up to 2.2 m (86") in diameter have been supplied and bearings up to 1.5 m (60") O.D. can be machined in-house.

Quality

Thordon Bearings Inc. is a Canadian company manufacturing to ISO 9001 Quality System requirements. With over 40 years experience in polymer bearing design, application engineering and manufacturing, Thordon marine and industrial bearings are recognized worldwide for both quality and performance.

Research and Development

Thordon bearings are being continuously tested by our Bearing Test Facility. The Facility evaluates new designs and applications before they are put into service. Ongoing testing not only allows for design refinements, but ensures quality and performance after installation. Our polymer laboratory evaluates new and modified polymers in a continuing quest to improve Thordon bearing performance and searches for new polymer bearing solutions.

Your Authorized Thordon Distributor

THORDON
THORDON BEARINGS INC.

3225 Mainway, Burlington, Ontario L7M 1A6 Canada

Tel: +1.905.335.1440 Fax: +1.905.335.4033 Email: info@thordonbearings.com Website: www.ThordonBearings.com



TPEM 04/26/NA
Printed in Canada