

Hydro-Turbine Main Shaft Axial Seals of Elastic Polymer – Principle and Practice

By Guojun (Gary) Ren, Applications Engineer, Ph.D. P. Eng
Ken Ogle, Engineering Director, C. Eng
Thordon Bearings Inc. Canada

ABSTRACT

The main shaft seal in a hydro-turbine is one of the key components of the turbine system. Ideally, the seal should seal completely but due the size of typical units such an arrangement is prohibitively expensive. The main shaft seal therefore functions not to eliminate leakage but more to control the leakage to an acceptable amount. The requirements on such seals include, but are not limited to, effective operation, long wear life, easy maintenance and low initial cost. The main shaft seal often operates under harsh working conditions. Two key challenges for the design are that the seal must provide high wear resistance against abrasives within the water and be able to operate at high rubbing velocities with low leakage.

Seals of elastic-polymer prevail in terms of combined benefits to meet these requirements. They are economical, non-brittle and able to provide a long service life – comparable to or longer than non-polymer seals in abrasive water environments. With careful design of factors such as seal surface finish, seal profile, installation and water pressure balancing, leakage rates comparable to or less than from other materials can be achieved.

There are generally two main types of seals in widespread service, differentiated by the orientation of the sealing face to the shaft axis -- these are radial and axial seals. For the larger shaft diameters (over 1000 mm), axial type seals are receiving more preference in recent years and after a brief overview of the different types, this paper focuses on axial seals only and discusses their working principle, design criteria and a case study.

1.0 Overview on main shaft seals

Perhaps the simplest and probably the oldest sealing effort is the labyrinth. The seal rings surfaces are often lined with white metal and depending on speed and shaft size there are small gaps from 0.2 to 0.4mm between the rotating shaft and the stationary seal rings. Obviously true sealing is not achieved but for small machines operating at low pressures acceptable leakage can be achieved. Labyrinth seals however are not frequently used for these applications.

Next in simplicity for a radial type seal is a stuffing box and these are still often used. When compressed, the soft packing material expands within the housing of the stuffing box and closes the clearance between the shaft and housing. Leakage rates are usually low however there are two main shortcomings for the stuffing box arrangement. First, abrasive silt in the water can become imbedded into the packing material and then scratch the shaft surface which then compromises the sealing efficiency. Second, it is necessary to maintain proper compression on the packing material so frequent manual adjustments of the gland follower are required during operation. Nowadays, stuffing boxes are usually applied to only small and middle size turbines.

Another commonly used radial seal is a carbon ring seal. This is a “segmented” shaft seal with carbon rings comprised of individual arc segments. There is a variety of designs for this type of seal and the general concept is to achieve some balance of water pressure between the rings to acquire a low leakage. One of the leakage paths in this type of seal is at the segment joints. The leakage for a segmented radial seal can vary from low to high depending on shaft size, number of rings per seal set, number of segments per ring, sealed water pressure and vibration. Drawbacks for segmented carbon seals are that they have poor resistance to abrasive wear and the material is brittle.

For shafts greater than 1000 mm, or when the sealed water pressure exceeds 1.0MPa, an axial type of seal arrangement is recommended. These are sometimes referred to as mechanical seals or face seals.

Mechanical face seals are also used as hydro-turbine main shaft seals. Traditional material for this type of seal is carbon with stainless steel or bronze as the mating surface. Carbon sizes are limited however and for large shaft diameters the carbon ring needs to be segmented. These seals tend to be relatively expensive and the large shaft sizes of hydro-turbines often make their cost uneconomical.

A variation of a flexible face seals where the sealing surface is a flat rubber ring and the mating surface is steel or other metal, has found many applications in Russia. The rubber ring can be held with a clamping ring bolted on either the outside or inside diameter. This design however has proved to be somewhat unreliable, especially for abrasive laden waters. See references 6, 7, 8.

A direct improvement of segmented carbon as a sealing face is the use of an elastic polymer. Thordon SXL combines the major advantages of carbon and a soft elastomeric material such as rubber. Thordon SXL can be easily machined to required sizes and exhibits high resistance to abrasive wear. Thordon Bearings Inc. has successfully designed SXL radial segmented seals that have been installed to shafts ranging from 300 mm to 2000 mm; however preferred shaft sizes for this variety of seal are normally from 400 mm to 1000 mm.

Axial segmented seals are mainly applied to large shaft diameter. Thordon Bearings Inc. has successfully designed and installed axial seals of SXL material up to 4000 mm in diameters.

2.0 Working principle of axial turbine shaft seal of elastic polymer

Although operating principles of a hydro-turbine axial seal may appear similar to those of smaller traditional mechanical face seals such as fitted to pumps etc, the size disparity between the two applications causes practical operation of the seals to differ considerably.

The flatness of the sealing surfaces in small mechanical seals is at a level of several light bands (one light band is 0.3 μ m) and consequently the friction coefficient and friction heat are very low, and there is virtually no visible leakage past the seal.

Due the much larger size of hydro-turbine seals, such level of sealing surface flatness cannot be economically achieved. Installation conditions tend to less friendly and the general nature of machine operation tends to harsher working conditions. Rather than microscopic “lightband” flatness, the sealing surface unevenness is macroscopic waves. While this unevenness is beneficial for hydrodynamic film formation and consequent low operating friction, it is also the cause of leakage past the seal.

Theoretically, only a very small fraction of the two mating surfaces will be in contact for a new seal installation and then as the machine operated, the seal surfaces would undergo ‘commissioning wear’ and the contact areas would gradually grow until they became continuous.

Only a few microns of relative movement are required to significantly change the sealing conditions and in practical service, the sealing surfaces are constantly being realigned to each other consequent to positional and dimensional changes in any of the machinery parts from, notably, varying temperatures, water pressures and even geological movement or settling. The sealing surfaces are therefore constantly ‘playing catch-up’ trying to wear into continuous flat sealing surfaces.

Within the contact patches only boundary, or even dry, lubrication can exist and it is in these regions where the majority of the heat within the seal is produced. Between the intermittent contact patches are gaps in the sealing effect. In these transient regions between contact patches, hydrodynamic water-wedges of differing size, geometry and slopes are developed.

Practical observations show that even when there is significant water flow across the sealing face there are still significant amounts of heat created by friction within the seal. The conclusion can be that the global tribological conditions on the sealing face are so complex that they range from dry, through boundary, mixed and full hydrodynamic lubrication, to direct cross-flow water path leakage.

Practice shows that leakage of axial seals is realistically unavoidable. Some leakage must occur to remove frictional heat and prevent seal from overheat. While it may be desirable to have “zero” leakage (where the leakage evaporates), as with smaller mechanical seals on pumps etc, practical economics require that the seal merely maintain leakage within an acceptable level.

The leakage rate depends on many factors, most of which can be qualified but cannot be easily quantified.

The abrasive resistance relies on two basic properties of the elastomer. These are elasticity and high tensile strength. In case solid particles trapped into between wear surfaces, they do not imbed into the body of the material and become a physical cutter. They deform the elastic surface locally and keep rolling between sealing faces until escaping the seal. This working mechanism had been confirmed by observations from elastomeric bearings and seals.

3.0 Major Factors Influencing Leakage

- **Size**

Hydro-electric equipment is typically large. The machining tolerance for the casing into which the polymer face ring gets installed may also be subsequently large, both on dimension and surface finish. This variance adds unevenness to the installed sealing surface. The polymer sealing ring is commonly fastened into its casing with bolts. This results in localized deformation in the vicinity of the fasteners with consequent distortion of the sealing surface. Large seal rings are manufactured from segments and any mismatch at a segment joints will result in increased leakage. Many springs are required to distribute the loading force around the (large) circumference. Since it is common for springs coming from any single manufacturer and from same batch to have a spring constant deviation up to 20%, it must be expected that the spring forces will vary resulting in varying contact conditions around the seal.

- **Surface finish of seal ring**

The characteristics of the material mean that a sealing face of elastic polymer cannot be machined or lapped to a very fine level of finish and flatness. Precise machining of such material is expensive and since the material may deform afterwards would be somewhat pointless. A typical surface finish is 1.6µm and depending on the size of sealing ring, the surface waves can be up to ± 0.25 mm. Even with a mating metal surface that is perfectly flat, gaps between the surfaces can therefore be as wide as 0.5mm. This is a huge gap from a sealing viewpoint and causes leakage.

- Thermal expansion and water swell

Polymer materials generally have higher coefficients of thermal expansion than metals. Differential expansion or contraction therefore occurs between the various parts when operating temperatures change. These differential dimension changes can cause small localized or global deformations of the polymer.

Many polymer materials can absorb water over time and this often causes a swell of the polymer—an increase in its bulk volume. While the volume increase may be very slow, its effects are similar to a thermal expansion and water swell of the polymer will also result in localized and/or global deformation of the polymer ring.

- Centrifugal force

The operation of the machine imparts rotary motion to the water being sealed with resultant centrifugal forces. Since these forces always act away from the shaft axis, they can encourage or discourage leakage across the seal face depending on the sealing direction. It is normal for the seal arrangement to be such that leakage across the seal is towards the shaft – i.e. for centrifugal forces on the water to act against leakage flow.

- Continuous Surface Wear

As discussed previously, theoretically the surfaces could eventually wear until they were perfectly flat against each other but microscopic changes in the operating conditions prevent this from ever reaching completion. The surface unevenness and distortion results in leakage, provides a semblance of hydrodynamic lubrication and the leakage itself removes heat generated and prevents seal from overheat.

- Static Leaking Path

As mentioned before axial seals consist of numbers of segments installed into machined steel groove (housing). Static leaking path includes all possible leaking paths other than dynamic sealing face. The main static leaking path is the joints of segments.

All above factors all influence the amount of leakage and they themselves constantly change during the service life of the seal. There are also unpredictable influences and since the main influencing factors are themselves changing over time, making a precise estimation of a leakage rate is impossible.

Field experience however does indicate that this seal type can maintain leakage rates at most installations to within acceptable levels. Records show the leakage can vary from 10 to 90 L/min. A similar design with smaller diameter has a lower level leakage than the large.

Leakage rates for polymer axial face seals in large size are comparable to, or less than, those for similar size carbon seals. The elastic polymer material possesses much greater resistance to abrasive wear than carbon and since in reality most turbine water contains abrasive particles to some extent, the advantages of a material such as Thordon SXL are self-evident.

4.0 General overview of design and arrangements

A typical axial turbine seal consists of the same several basic components no matter how they may be actually configured in any given design. These are the seal holder (usually is stationary), the static seal, load spring, polymer sealing surface, mating surface and cooling water injection with throttle valve, **Figure -1** shows a common arrangement.

Figure -1: Typical arrangement of a turbine axial seal

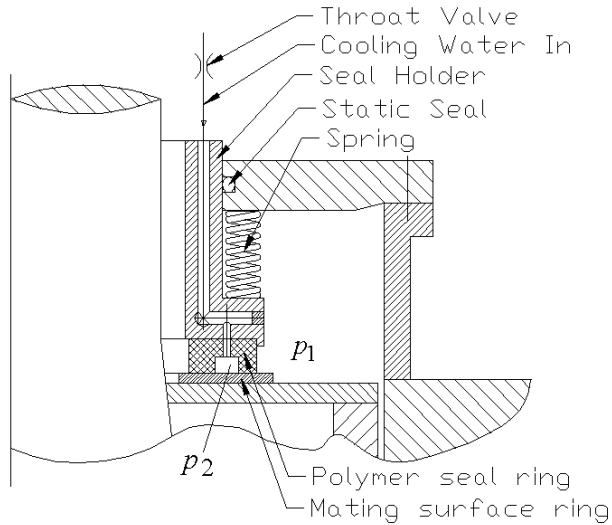

Small relative movement is required vertically between the static seal and the seal holder to compensate for wear in the dynamic seal and it is important that materials here are chosen carefully to ensure corrosion debris, or other, does not interfere with that sliding action.

The springs need to be carefully selected in number, stiffness and strength to provide optimum contact pressure evenly distributed around the sealing surface.

When using a polymer sealing face there are some additional points that the designer must consider from the start of the design process. The seal holder should provide a shoulder to support the outside diameter of the polymer seal ring. This shoulder confines the seal ring from outward expansion and maintains the segments properly in position while limiting local stresses from the fastening bolts. It is preferred to put the polymer seal ring into the seal holder as the stationary ring while the mating metal surface rotates with the turbine shaft.

The area ratio A_1 / A (**Figure -2**) has a large influence on pressure balancing of the seal and must be carefully selected at the discretion of turbine/seal designer(s). For high head turbines, this ratio should be smaller than for lower head machines.

Figure - 2: Area balance Ratio

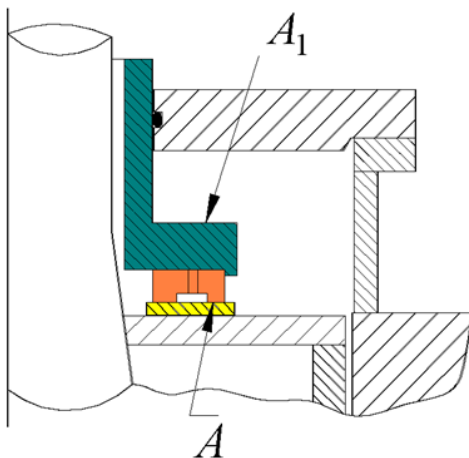

The typical segment design of a turbine axial seal is quite simple. The cross section of the segments is rectangular in shape with a circumferential water groove offset a little from the mid-diameter. Holes for the fastening bolts and injection water inlets usually pass from the water groove through to the opposite side of the part, see **Figure -3**.

The circumferential central water groove divides the 'sealing face' into two concentric sealing faces, A and B. To limit the amount of abrasives introduced to the seal, it is normal to feed the water groove with filtered injection water at a pressure higher than the turbine water and this injection water then proportionally passes across both surfaces A and B. The pressure difference across face A is the differential between injection and turbine pressures whereas across B the drop is from injection pressure to zero (atmosphere pressure). In order to promote more injection water flow into turbine rather than becoming leakage, sealing face A on the turbine water side is always narrower than the sealing face B on the leakage side. Various designs use different ratios for the faces A to B, but as a rule of thumb the width ratio B/A is typically between 1.3 and 2.0. It is rare to see a ratio greater than 2.0 in design practice. Larger ratios tend towards lower external leakage, but also tend towards overheating the wider sealing face B.

Figure - 3: Segment cross section of an axial turbine seal ring

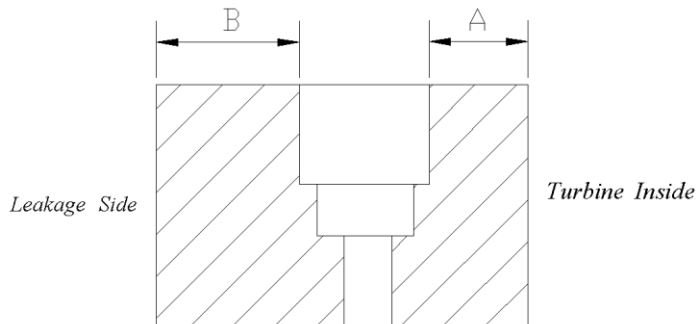

It is preferable to make the ring in one piece but for large designs such may be impractical and the ring is constructed from segments. Simple segments placed tightly end to end would at first seem suitable and tight end butts would suitably restrict direct leakage. Any cooling of the segments however would cause thermal shrinkage and opening of the butt joints which could quickly lead to excessive leakage – simple butt-joined size to size segments can therefore only be used when operating temperatures are clearly defined with only small deviations.

A challenging part of seal segment design therefore is the inter-segment join and this is typically configured to maintain acceptable leakage while accommodating thermal expansion and contraction of the material.

To ensure there is no direct leak path at the segment ends, some sort of an overlapped joint is recommended. The overlap design should also provide a means to accommodate thermal expansion or contraction of the segments in the circumferential direction. Commonly used overlaps are simple overlapping and fork type overlapping as shown in, **Figure -4**.

For fork type overlaps it is possible to continue the central groove through the joint (not shown).

Figure -4: Segment joint with overlapping

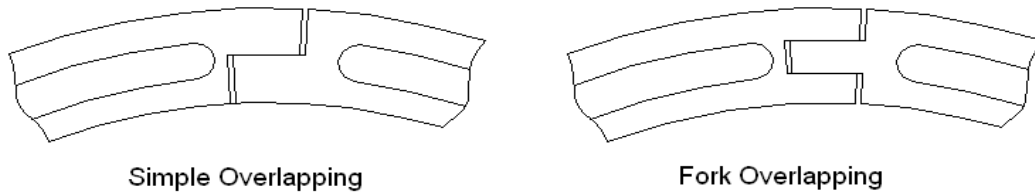

5.0 Balancing water and pressure control

With consideration of continuously varying friction between machine parts, fluctuating temperatures and pressures of both injected and sealed water, any precise calculations of force balancing for an axial seal quickly become quite complicated.

Figure – 5 illustrates the major forces acting on the free-body of the seal (seal holder and elastic polymer seal ring together). F_S is the total spring force, F_f is the net friction force from all interactive parts, W is the total gravitational weight and F_C is the solid interactive contact force between the seal mating surfaces. p_1 is the turbine water pressure to be sealed -- note that p_1 is usually not equal to the head pressure since the head pressure is usually already reduced by some intermediate labyrinth type seals. p_2 is hydraulic pressure in the seal water groove and as a rule of thumb, $p_2 \approx (1.1-1.15) \cdot p_1$.

For design purposes, it is assumed that the pressure distribution across the 2 seal faces is linearly distributed between the higher and lower pressure regimes.

Figure -5: Forces acting on axial turbine seals

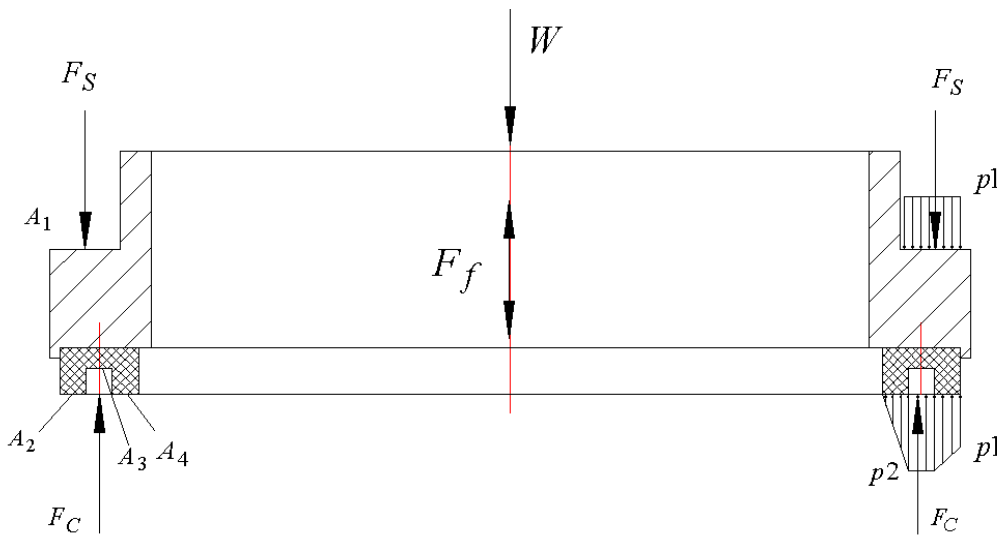

The hydraulic force tending to open the seal is:

$$F_o = \frac{(p_1 + p_2)}{2} \cdot A_2 + p_2 \cdot A_3 + \frac{p_1}{2} \cdot A_4$$

And the hydraulic force tending to close the seal is:

$$F_L = A_1 \cdot p_1$$

The solid contact force between seal ring and mating ring should be

$$F_C = F_L + F_S + W \pm F_f - F_o$$

By using the solid inter contact force, the inter contact pressure can be estimated as

$$p_C = \frac{F_C}{A_2 + A_4}$$

With accurate determination of all forces, the contact force could be effectively be controlled at zero to avoid frictional losses without any increased leakage penalty, however in practice the friction and hydraulic forces cannot be precisely predicted.

The essence for a good design is to investigate the possible hydraulic and friction force scenarios and try to keep the contact force as low as possible. From field experience, keeping this contact pressure at about 50kPa (0.5bar) or lower yields satisfactory operation.

Once the solid contact force is calculated, the required cooling water flow rate can be estimated from

$$Q = \frac{\mu \cdot F_C \cdot V}{C_p \cdot \rho \cdot \Delta T}$$

Water flow, Q is in m^3/s , where C_p - Specific heat of water =4180Nm/kg-C, ρ - density of water= 1000kg/m³, ΔT – temperature rise allowance (5degC), V – rubbing speed of sealing face (m/s), and μ - coefficient of friction (0.1 to 0.15).

The throttle valve in the water injection system is an important component and its characteristics should be carefully chosen as it can provide a degree of self-adjustment to the injection water pressure. The pressure drop through the throttle valve is proportional to the flow rate so assuming the injection water pump maintains a constant supply pressure, the pressure after the throttle valve is then related to the flowrate. If for some reason the leakage across the seal should increase then the pressure drop through the throttle valve will correspondingly also increase. The pressure of injection water at the seal is therefore decreased and the force balance on the seal is altered so the closing forces predominate. Lower water pressure and a ‘closed’ seal both act to reduce the water leakage until conditions at the seal become re-balanced. Similarly, the reverse occurs should the leakage reduce.

Injection water pressure must be carefully selected to maintain sufficient leakage through the seal for cooling purposes through the whole turbine operating range.

6.0 Case study of performance of a carbon axial shaft seal retrofitted with Thordon SXL

Towards the end of 2003 Thordon Bearings Inc (TBI) were contacted by the operators of one of the largest hydro-electrical power plants in the world in connection with retrofitting the seal on one of their operating Francis-type vertical turbines. The existing seal was an axial face type using a segmented carbon ring with average diameter 4000mm. The seal leakage was high and the segments were suffering from severe abrasive wear from sand in the water. The segmented carbon seal is very brittle and there was concern about the extreme care required when performing maintenance work.

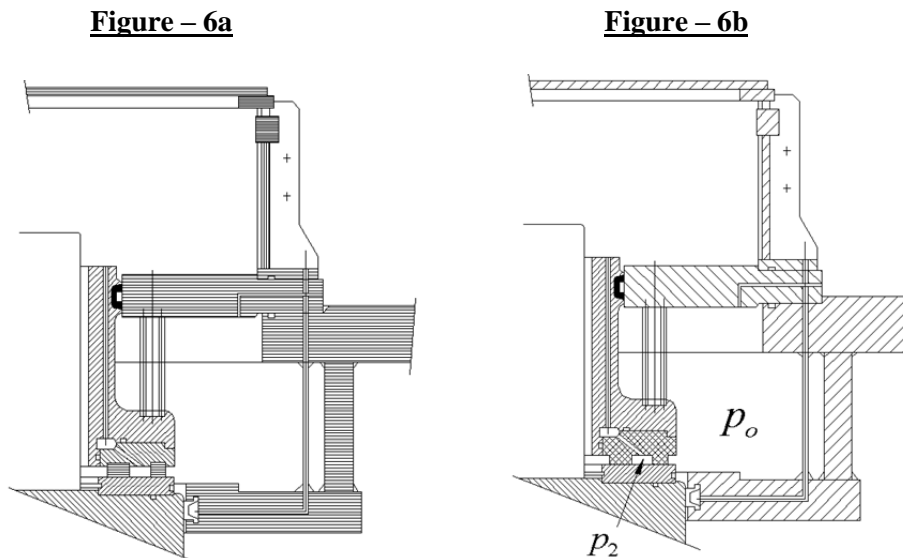

Figure-6a shows the arrangement of the original seal. Two carbon rings, each comprised of many small segments, were installed into two separate grooves of the steel carrier ring.

Figure-6b shows the modified arrangement suggested by TBI. The two carbon rings and their steel carrier were replaced by a single ring of profiled SXL material. The SXL ring comprised of only six segments.

A major consideration of the proposed change was that the original steel ring was about 400kg in weight while the SXL sealing ring was less than 100kg, a difference of over 300kg to the balancing conditions of the seal. Thordon's engineers carefully examined the force balance conditions. The study indicated that changes to the original springs would be unnecessary as calculations indicated the existing spring force would be sufficient to keep the sealing face closed.

The seal was installed by the end of 2005 and the plant engineers had created a detail plan to test the seal's performance during re-start of the turbine and in service. Accordingly, the seal was tested under different conditions. As the turbine was re-started, the leakage rate and temperature increase of leakage water were carefully recorded for still stand condition, runner operating at 15 rpm and at full speed (90 rpm), all results were satisfactory.

The cooling water pressure, water supply flow, leakage rate and temperature increase were all then carefully monitored for the next year, during first two months the reading were taken daily and for the months thereafter, the reading interval was extended to twice a week. Initial feedback from the plant

engineers were that conditions all seemed satisfactory and the leakage was less than from the previous carbon seal. The original seal leaked about 140 L/min.

After some time, the operators again contacted TBI with concerns that the leakage rate had further reduced. While delighted that the leakage was small they were concerned that was perhaps too low. And would compromise the longevity of the seal as they thought perhaps it would overheat.

With review of the temperature rise within the injection water and its outlet temperature, TBI advised that it seemed the seal was not overheating and operation of the machine should continue.

Leakage rates continued to fluctuate a little but were always considerably less than from the previous carbon seal. **Figure -7** was measured leakage data from 20. December 2005 to 02 Aug. 2006. The water temperature was measured during the same period of time. Inlet water is the water injected into central groove of seal and outlet water is the leakage water. The record is presented in **Figure -8**.

The cooling water flow was kept constantly at 240 L/min with a pressure at 3.0 bars. The leakage is about 4% to 38% of this injection water. This means there was significant counter flow into turbine and effectively block abrasive from entering into seal.

Figure-7: Measured leakage rate

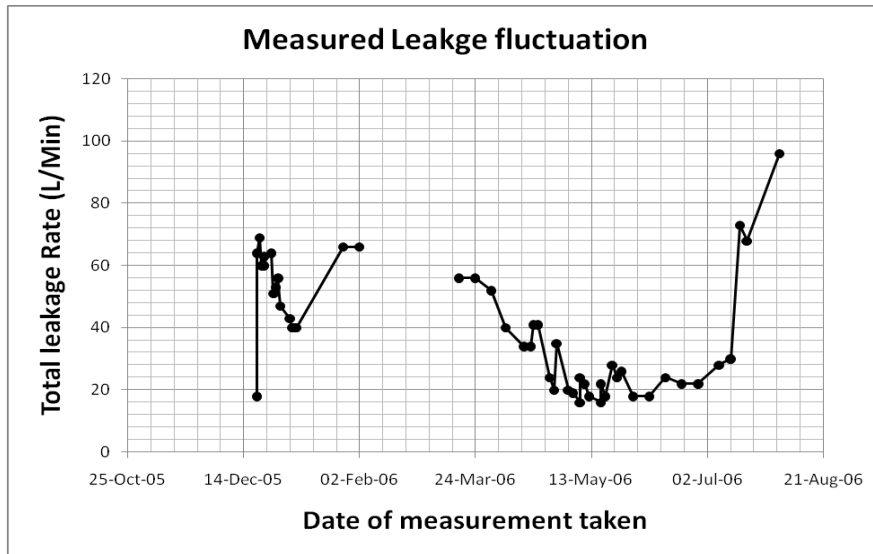

After one year's operation, the turbine was taken apart for inspection by end of 2006.

After opening the seal, the sealing face to the turbine water was clean and since the machining marks were still visible there had been negligible wear if any. The sealing face on the leakage side however had several regions that appeared discolored dark and there were some film like material partially adhered / detached from the seal face. It was immediately suspected (incorrectly) that these were indications of overheat and seal problems.

Most of the discoloration and the adhering films however were removed with simple cleaning and the sealing surface then appeared very smooth.

Figure -8: Measured inlet and outlet water temperature

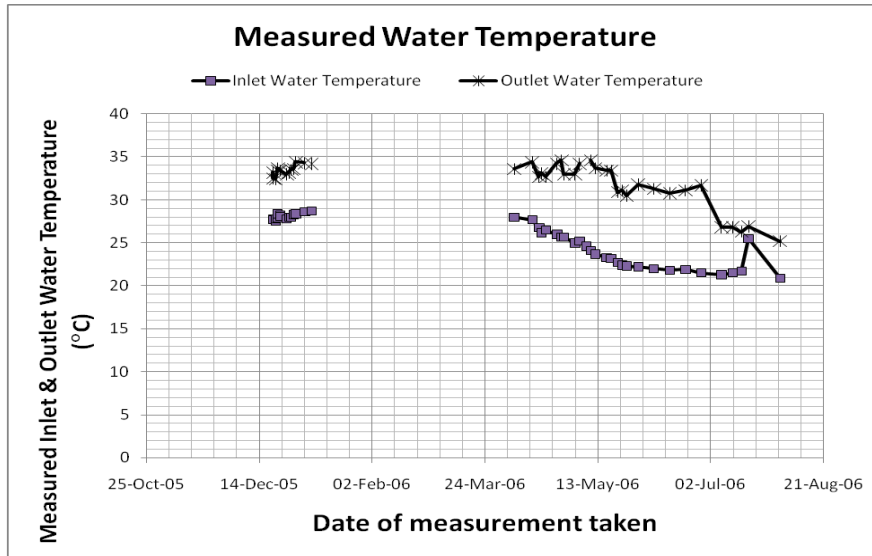

Figure -9, shows the seal after cleaning. The sealing face on left is the leakage side towards the shaft, the sealing face to the right is to the turbine water.

Figure – 9: Sealing faces after cleaning



The brown coloured film substance taken from the sealing surface was sent to Thordon for composition study. Thordon tested the content of substance and it was determined 60% of it was organic from the process water and 40% was SXL material removed from sealing surface.

Precise dimensional measurements of the seal were recorded and only one small section had worn by 0.1mm, wear in other areas was effectively undetectable. Accordingly, it was predicted that the seal should work for the 20 years requirement.

In light of the successful installation, the operators similarly changed the seal for one of the sister turbines in earlier 2007 and now these two turbines are all running satisfactorily.

7.0 Conclusions

A turbine axial shaft seal using elastic polymer offers great advantages to the turbine operator. It provides

1. robust construction
2. fewer segments required for larger sizes
3. simple material manufacture with standard conventional machining techniques
4. reliable operation and long life
5. economical

For reliable and long operation, optimum design must consider all components of the overall arrangement, force balance, and careful component selection.

Thordon Bearings Inc is pleased to review enquiries from turbine operators, turbine manufacturers, turbine repairers and seal suppliers for incorporation of Thordon materials to enhance the operating characteristics of the machinery.

(Feb 09, 2009)

References:

- /1/ Crane Packing Company, Packing and Mechanical seals, Norton Grove, Illinois, 1973
- /2/ Arne Kjolle, Hydropower in Norway, Mechanical Equipment, Trondheim, Dec. 2001
- /3/ N. N. Kovalev, Hydro-Turbines, Design and Construction, Israel Program for Scientific Translations Jerusalem 1965
- /4/ Mark Syer, Sealing the deal for Kaplan turbines, International water and dam construction, March 2006, Progressive Media Markets Ltd
- /5/ A. A. Zakharov, Adjustment of a bronze-graphite Turbine shaft seal after repair, Hydro-technical Construction, Vol. 29, No 4. 1995
- /6/ B. B. Aitkeev, Operation of shaft seals in hydroelectric sets of the UCH-KURGAN HPP, Power Technology and Engineering, Vol. 36, No 2. 2002
- /7/ V. Ya. Monchares and A. I. Sitnyanskii, Increase of operational reliability of turbine components at the VILYUI-2 hydroelectric station, Gidrotekhnicheskoe Stroitel'stvo, No. 9, pp, 5-8, September, 1985
- /8/ I. S. Gurbanov, Experience in the operation of hydraulic structure and equipment of hydroelectric stations, Gidrotekhnicheskoe Stroitel'stvo, No. 1, pp, 28-29, January, 1984
- /9/ Cheng-Jun Li, Sealing the Shaft , International Water Power and Dam Construction, June 1996, pp, 26 - 27

Authors:

Guojun (Gary) Ren is a senior Applications Engineer. Gary worked as an engineer with ThyssenKrupp Elevator before joining Thordon bearings Inc. in 2001. Gary acquired his Ph.D. of mechanical engineering from University of Stuttgart in Germany in 1996.

Ken Ogle is the Engineering Director for Thordon Bearings Inc. Previously Ken climbed the ranks as a sea-going Engineering Officer with the P&O Steam Navigation Company before working as Senior surveyor in the Technical Investigation Dept of Lloyd's Register of Shipping.